

## FEATURES

- > Tungsten contacts improve hot load switching \*\*
- > Coil choices of 5, 12 or 24Vdc accommodate virtually any drive circuit
- > All PC pin or PC pin & flying lead connections provide mounting and connection versatility
- > Vacuum dielectric provides low and stable contact resistance

## PRODUCT SPECIFICATIONS

Contact & Relay Ratings	Units	GR5LTB
Contact Form		B
Contact Arrangement		SPST-NC
Contact Material		Tungsten
Dielectric		Vacuum
Voltage, Operating Max	kV Peak	10
Current, Continuous Carry Max - not switching	Amps	5*
Resistance, Contact Max	ohms	0.250
Capacitance		
Across Open Contacts	pF	1
Closed Contacts to Ground	pF	8
Operate Time*	ms	2
Release Time*	ms	2
Life, Mechanical	cycles	one billion
Weight, Nominal	g (oz)	28 (1)
Vibration, Operating, Sine ((10-500 Hz Peak)	G's	20
Shock, Operating, 1/2 Sine 11ms (Peak)	G's	100
Temperature Ambient Operating		
Operating	°C	-20 to +70
Storage	°C	-35 to +110

## COIL RATINGS

Nominal, Volts dc	5	12	24
Pick-up, Volts dc, Max.	4	10	21
Drop-Out, Volts dc	.5	2	4
Coil Resistance (Ohms ±10%)	38	240	925

\* Operation and release times are with external diode suppression, @ 25°C

\*\* See table below or consult factory for load switching applications.

## PART NUMBER SYSTEM

GR5LTB	3	3	5
Coil Voltage	1 = 5 Vdc 2 = 12 Vdc 3 = 24 Vdc		
High Voltage Connections		3 = PCB Pins 4 = Flying Leads	
Mounting			5 = PC Board

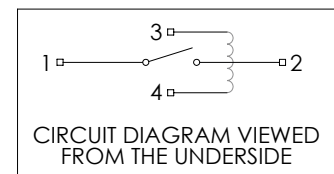
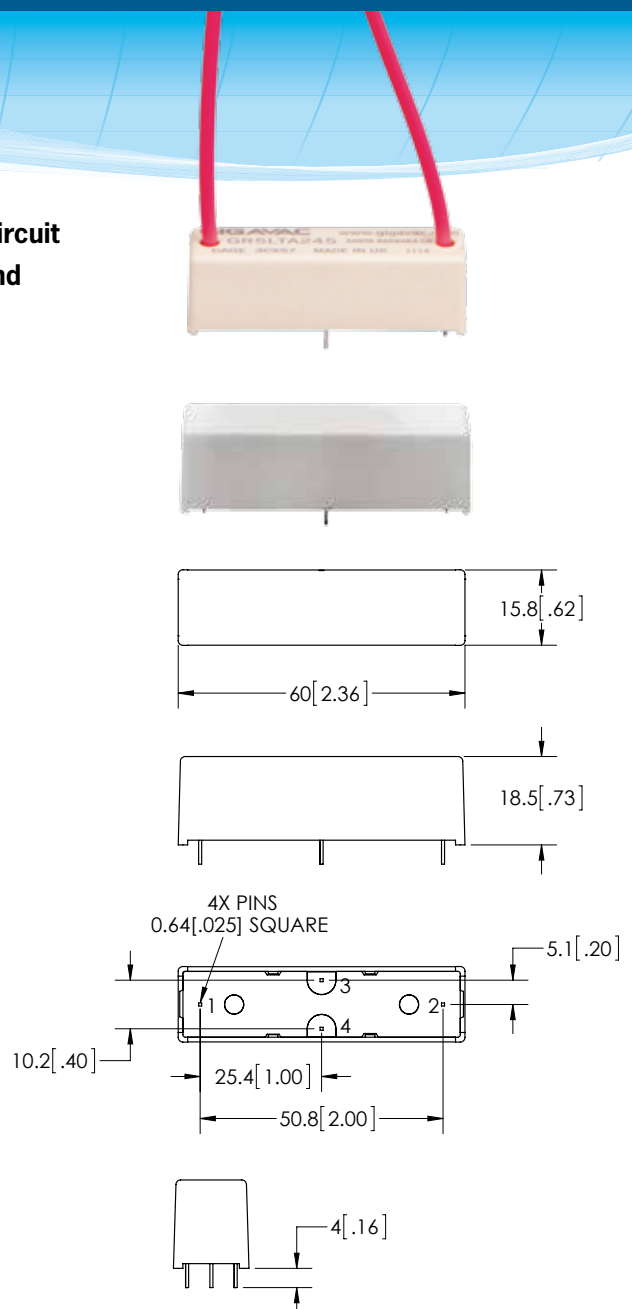

## \*\* LOAD SWITCHING

Voltage (VAC)	Current (A)	Life (Cycles)
110	0.5	1,000,000
120	1.0	200,000
1000	0.200	100,000
5000	0.083	1,000

---

Datasheets provided by Sensata Technologies, Inc., its subsidiaries and/or affiliates (“Sensata”) are solely intended to assist third parties (“Buyers”) who are developing systems that incorporate Sensata products (also referred to herein as “components”). Buyer understands and agrees that Buyer remains responsible for using its independent analysis, valuation, and judgment in designing Buyer’s systems and products. Sensata datasheets have been created using standard laboratory conditions and engineering practices. Sensata has not conducted any testing other than that specifically described in the published documentation for a particular datasheet. Sensata may make corrections, enhancements, improvements, and other changes to its datasheets or components without notice.

Buyers are authorized to use Sensata datasheets with the Sensata component(s) identified in each particular datasheet. HOWEVER, NO OTHER LICENSE, EXPRESS OR IMPLIED, BY ESTOPPEL OR OTHERWISE TO ANY OTHER SENSATA INTELLECTUAL PROPERTY RIGHT, AND NO LICENSE TO ANY THIRD PARTY TECHNOLOGY OR INTELLECTUAL PROPERTY RIGHT, IS GRANTED HEREIN. SENSATA DATASHEETS ARE PROVIDED “AS IS”. SENSATA MAKES NO WARRANTIES OR REPRESENTATIONS WITH REGARD TO THE DATASHEETS OR USE OF THE DATASHEETS, EXPRESS, IMPLIED, OR STATUTORY, INCLUDING ACCURACY OR COMPLETENESS. SENSATA DISCLAIMS ANY WARRANTY OF TITLE AND ANY IMPLIED WARRANTIES OF MERCHANTABILITY, FITNESS FOR A PARTICULAR PURPOSE, QUIET ENJOYMENT, QUIET POSSESSION, AND NON-INFRINGEMENT OF ANY THIRD PARTY INTELLECTUAL PROPERTY RIGHTS WITH REGARD TO SENSATA DATASHEETS OR USE THEREOF.

All products are sold subject to Sensata’s terms and conditions of sale supplied at [www.sensata.com](http://www.sensata.com). SENSATA ASSUMES NO LIABILITY FOR APPLICATIONS ASSISTANCE OR THE DESIGN OF BUYERS’ PRODUCTS. BUYER ACKNOWLEDGES AND AGREES THAT IT IS SOLELY RESPONSIBLE FOR COMPLIANCE WITH ALL LEGAL, REGULATORY, AND SAFETY-RELATED REQUIREMENTS CONCERNING ITS PRODUCTS, AND ANY USE OF SENSATA COMPONENTS IN ITS APPLICATIONS, NOTWITHSTANDING ANY APPLICATIONS-RELATED INFORMATION OR SUPPORT THAT MAY BE PROVIDED BY SENSATA.

Mailing Address: Sensata Technologies, Inc., 529 Pleasant Street, Attleboro, MA 02703, USA

## CONTACT US

### Regional head offices:

#### United States of America

Sensata Technologies

Attleboro, MA

**Phone:** 508-236-3800

**E-mail:** [support@sensata.com](mailto:support@sensata.com)

#### Netherlands

Sensata Technologies Holland B.V.

Hengelo

**Phone:** +31 74 357 8000

**E-mail:** [support@sensata.com](mailto:support@sensata.com)

#### China

Sensata Technologies China Co., Ltd.

Shanghai

**Phone:** +8621 2306 1500

**E-mail:** [support@sensata.com](mailto:support@sensata.com)

Copyright © 2023 Sensata Technologies, Inc.