

ATEX ABSOLUTE CANopen MULTI TURN ENCODER, PAUX RANGE

ATEX certified Explosion-proof encoders according to Directive 94/9/CE

Explosion-proof rotary encoders for hazardous environments gas & dust
Robust design for heavy-duty applications
Hollow through shaft up to 30mm
Application fields: explosive atmospheres except for firedamp mines

EC type examination certificate
Download from our website www.beisensors.com

LCIE 03 ATEX 6407
CE0081

II 2 G/D

Ex d IIC T6, T5 or T4

Ex tD A21 IP6X T80°C T95°C T100°C

CANopen
DS 301 V4.02
DS 406 V3.1



PAUX_30 connection B2R (radial cable)

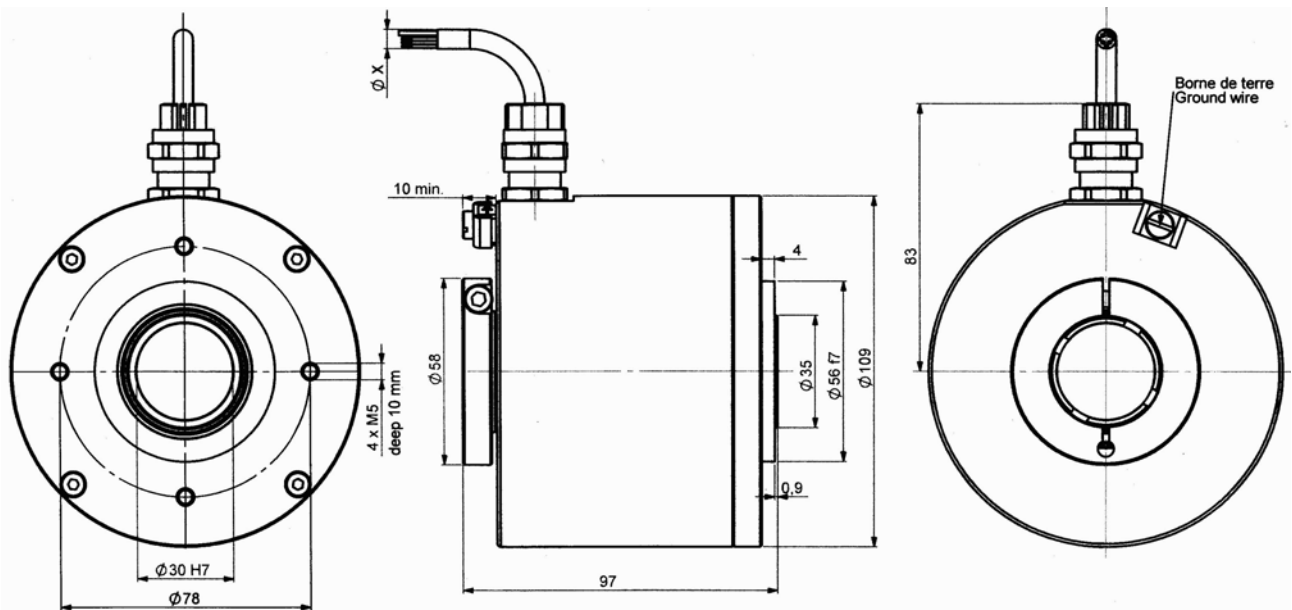

Material	Cover: aluminium
Stainless steel option	Body: aluminium
Shaft	Stainless steel
Bearings	6807 serie
Maximal load	Axial : 50 N
	Radial : 80 N
Shaft Inertia	$\leq 50 \cdot 10^{-6}$ kg.m ²
Torque	$\leq 25 \cdot 10^{-3}$ N.m
Permissible max. speed	4 500 min ⁻¹
Continuous max speed	3 000 min ⁻¹
Shaft seal	Viton

Shock (EN60068-2-27)	≤ 500 m.s ⁻² (during 6 ms)
Vibration (EN60068-2-6)	≤ 100 m.s ⁻² (10 ... 2000 Hz)
EMC	EN 61000-6-4, EN 61000-6-2
Isolation	500 V (1 min.)
Weight	2kg aluminium version
	5kg stainless steel version
Operating temperature	- 20... + 80 °C
Storage temperature	- 20... + 80 °C
Protection(EN 60529)	IP 65
Theoretical mechanical lifetime 10 ⁹ turns (F _{axial} / F _{radial})	
25 N / 40 N : 140	50 N / 80 N : 17

T _{amb}	Temperature class for gas atmosphere	Temperature class for dust atmosphere
-20°C ≤ Ta ≤ +40°C	T6	T80°C
-20°C ≤ Ta ≤ +55°C	T5	T95°C
-20°C ≤ Ta ≤ +60°C	T4	T100°C

ATEX ABSOLUTE CANopen MULTI TURN ENCODER, PAUX RANGE

ELECTRICAL CHARACTERISTICS

Power supply	5 – 30Vdc
Introduction	< 1 s
Consumption (without load)	< 50mA (at 24Vdc)
Accuracy	± ½ LSB (13 bits)

Programmable parameters

Resolution: defines the resolution per revolution (0 to 8 192),
Global resolution : total amount of codes for the encoder (2 to 536 870 912),
Transmission speed : programmable from 10kbaud (1000m) to 1 Mbaud (40 m) ; value per default: 20 Kbaud,
Address: define the software address of the encoder on the bus (1 to 127, value by default: id = 1),
Direction : define the direction of count of the encoder ,
RAX : defines the value of its preset position (non turning shaft),
CAM: Low and High Limits.

Communication modes

3 modes are available to interrogate the encoder :
POLLING mode: (Response to a RTR message): The position value is only given upon request (SDO mode),
CYCLIC mode: the encoder transmits its position in an asynchronous manner. The frequency of the transmission is defined by the programmable cyclical timer register from 0 to 65 535 ms,
SYNCHRO mode: the encoder transmits its position on a synchronous demand by the master.

CANopen CONNECTION

Blue	Black	White	Red
CAN LOW	0V	CAN HIGH	11/30Vdc

Nota : Refer to the bus standards for the maximal derivation length.

ORDERING REFERENCE

	Shaft Ø	Power supply	Output stages	Code	Resolution	Nb of turns	Connection	Connection orientation
PEUX (stainless steel)	30:30mm	P : 5 to 30Vdc	BB : CANopen	B: Binary	13 : 8192 points per turn (2 ¹³)	B16 : 65 536 turns (2 ¹⁶)	B2: cable PUR	Example :
PAUX (aluminium)								R020 : 2m radial cable
PEUX	_ 30 //	P	BB	B //	13	B16 //	B2	R050

ASSEMBLY CAUTION

NEVER OPEN THE ENCODER

NEVER CONNECT/DISCONNECT UNDER POWER SUPPLY/IN PRESENCE OF DUSTS ATMOSPHERE

The customer obliges to take up and to use our products, according to our specifications and to the manners of the profession. Our company would not be responsible for any defect resulting from a defective or erroneous assembly. From a use superior to the standard, or in abnormal conditions. The breakdowns resultant of shocks, bad electric supply, put in low capacity or overcapacity of the product, the environment of bad conditions (humidity, projection, dust, etc) cannot be imputed to us. The converter doesn't require any maintenance. Any encoder presenting a dysfunction will have to be the object of immediate return for control in our facilities. The encoder mustn't be open in any case (cable gland and/or cover).

An earth situated on the cover must be linked with the ground of the installation.

Made in FRANCE

ATEX ABSOLUTE CANopen MULTI TURN ENCODER, PAUX RANGE

1) Déclaration de conformité CE

2) Nous, société BEI Sensors, certifions que ce matériel :
capteurs antidéflagrants, type

GAUX, CAUX, PAUX, GEUX, CEUX, PEUX

3) Avec les inscriptions suivantes :

CE 0081  II 2 G/D, Ex d II C T6, T5 ou T4
Ex tD A21 IP6X T80°C T95°C T100°C

A été conçu et fabriqué conformément à la directive applicable suivante :

ATEX directive 94/9/CE

Directive CEM 89/336/CEE

4) La certification a été obtenu grâce à l'application des normes suivantes :

EN 60079-0 (2006), EN 60079-1 (2004), EN 61241-0 (2004) et EN 61241-1 (2004)

5) Une attestation d'examen CE de type a été obtenu :

LCIE 03 ATEX 6407

et une notification :

LCIE 03 ATEX Q8060

6) L'application des normes suivantes a participé à l'obtention de la certification :

EN 60-529, NFC 23-520, NFC 23-539, EN 50081-1, EN 55022 classe B, EN 55014, EN 61000-6-2, CEI 61000-4-2, CEI 61000-4-3, CEI 61000-4-4, CEI 61000-4-5, CEI 61000-4-6, CEI 61000-4-8, CEI 61000-4-11

7) L'organisme notifié responsable du suivi de la directive **ATEX** est le

LCIE, B.P.8, F92260 Fontenay-aux-Roses

Numéro d'identification : 0081

8) La société chargée de la certification **CEM** est nommée ci-après :

GRME, Cellule CEM, B.P.8, 68840 Pulversheim

9) Nous certifions que nos produits désignés ci-dessus sont conformes à la directive et aux normes spécifiées

Date :

ATEX Certified Product Approved Person

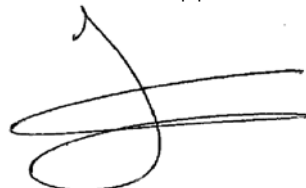

1) Declaration of conformity EC

2) We, BEI Sensors, certify that this material :
sensor explosion-proof standard

GAUX, CAUX, PAUX, GEUX, CEUX, PEUX

3) With the following inscriptions :

CE 0081  II 2 G/D, Ex d II C T6, T5 or T4
Ex tD A21 IP6X T80°C T95°C T100°C

Conceived and manufactured has the directive applicable following :

ATEX directive 94/9/CE

Directive CEM 89/336/CEE

4) Certification to summer obtained thanks to the application of the standards :

EN 60079-0 (2006), EN 60079-1 (2004), EN 61241-0 (2004) and EN 61241-1 (2004)

5) EC type examination certificate was obtained :

LCIE 03 ATEX 6407

and a notification :

LCIE 03 ATEX Q8060

6) The application of the following standards took part in obtaining certification :

EN 60-529, NFC 23-520, NFC 23-539, EN 50081-1, EN 55022 classe B, EN 55014, EN 61000-6-2, CEI 61000-4-2, CEI 61000-4-3, CEI 61000-4-4, CEI 61000-4-5, CEI 61000-4-6, CEI 61000-4-8, CEI 61000-4-11

7) The notified organization responsible for the follow-up of the directive **ATEX** is the

LCIE, B.P.8, F92260 Fontenay-aux-Roses

Identification number : 0081

8) The company in charge of certification **CEM** is named :

GRME, Cellule CEM, B.P.8, 68840 Pulversheim

9) We certify that our indicated products so above are in conformity with the directive and the specified standards

Datasheets provided by Sensata Technologies, Inc., its subsidiaries and/or affiliates (“Sensata”) are solely intended to assist third parties (“Buyers”) who are developing systems that incorporate Sensata products (also referred to herein as “components”). Buyer understands and agrees that Buyer remains responsible for using its independent analysis, valuation, and judgment in designing Buyer’s systems and products. Sensata datasheets have been created using standard laboratory conditions and engineering practices. Sensata has not conducted any testing other than that specifically described in the published documentation for a particular datasheet. Sensata may make corrections, enhancements, improvements, and other changes to its datasheets or components without notice.

Buyers are authorized to use Sensata datasheets with the Sensata component(s) identified in each particular datasheet. HOWEVER, NO OTHER LICENSE, EXPRESS OR IMPLIED, BY ESTOPPEL OR OTHERWISE TO ANY OTHER SENSATA INTELLECTUAL PROPERTY RIGHT, AND NO LICENSE TO ANY THIRD PARTY TECHNOLOGY OR INTELLECTUAL PROPERTY RIGHT, IS GRANTED HEREIN. SENSATA DATASHEETS ARE PROVIDED “AS IS”. SENSATA MAKES NO WARRANTIES OR REPRESENTATIONS WITH REGARD TO THE DATASHEETS OR USE OF THE DATASHEETS, EXPRESS, IMPLIED, OR STATUTORY, INCLUDING ACCURACY OR COMPLETENESS. SENSATA DISCLAIMS ANY WARRANTY OF TITLE AND ANY IMPLIED WARRANTIES OF MERCHANTABILITY, FITNESS FOR A PARTICULAR PURPOSE, QUIET ENJOYMENT, QUIET POSSESSION, AND NON-INFRINGEMENT OF ANY THIRD PARTY INTELLECTUAL PROPERTY RIGHTS WITH REGARD TO SENSATA DATASHEETS OR USE THEREOF.

All products are sold subject to Sensata’s terms and conditions of sale supplied at www.sensata.com. SENSATA ASSUMES NO LIABILITY FOR APPLICATIONS ASSISTANCE OR THE DESIGN OF BUYERS’ PRODUCTS. BUYER ACKNOWLEDGES AND AGREES THAT IT IS SOLELY RESPONSIBLE FOR COMPLIANCE WITH ALL LEGAL, REGULATORY, AND SAFETY-RELATED REQUIREMENTS CONCERNING ITS PRODUCTS, AND ANY USE OF SENSATA COMPONENTS IN ITS APPLICATIONS, NOTWITHSTANDING ANY APPLICATIONS-RELATED INFORMATION OR SUPPORT THAT MAY BE PROVIDED BY SENSATA.

Mailing Address: Sensata Technologies, Inc., 529 Pleasant Street, Attleboro, MA 02703, USA

CONTACT US

Regional head offices:

United States of America

Sensata Technologies

Attleboro, MA

Phone: 508-236-3800

E-mail: support@sensata.com

Netherlands

Sensata Technologies Holland B.V.

Hengelo

Phone: +31 74 357 8000

E-mail: support@sensata.com

China

Sensata Technologies China Co., Ltd.

Shanghai

Phone: +8621 2306 1500

E-mail: support@sensata.com

Copyright © 2023 Sensata Technologies, Inc.