

MAGNETIC ENCODERS - ANALOG ABSOLUTE SINGLE TURN - AXM4 RANGE

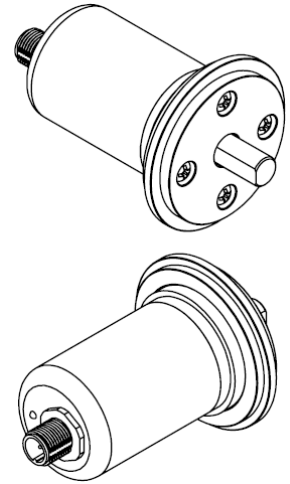

AXM4, single-turn encoder – 58mm servo flange - with analog output :

- Robust and compact conception.
- Heavy-duty conception : Stainless steel – IP69K.
- Solid shaft \varnothing 10 mm version.
- Precision ball bearings.
- High temperature performances -40°C to 85°C .
- Magnetic technology encoder.
- Analog output : 4-20mA, 0-20mA, 0.5-5Vdc, 0-5Vdc or 0-10Vdc,
- Analog output calibration possibility (minimum angle 22.5° angle).
- Resolution : 12 bits.
- Polarity inversion and over-voltage-peak protection.
- Highly integrated circuit in SMD-technology.



DIMENSIONS AXM4S10 M12 AXIAL WITH SERVO FLANGE

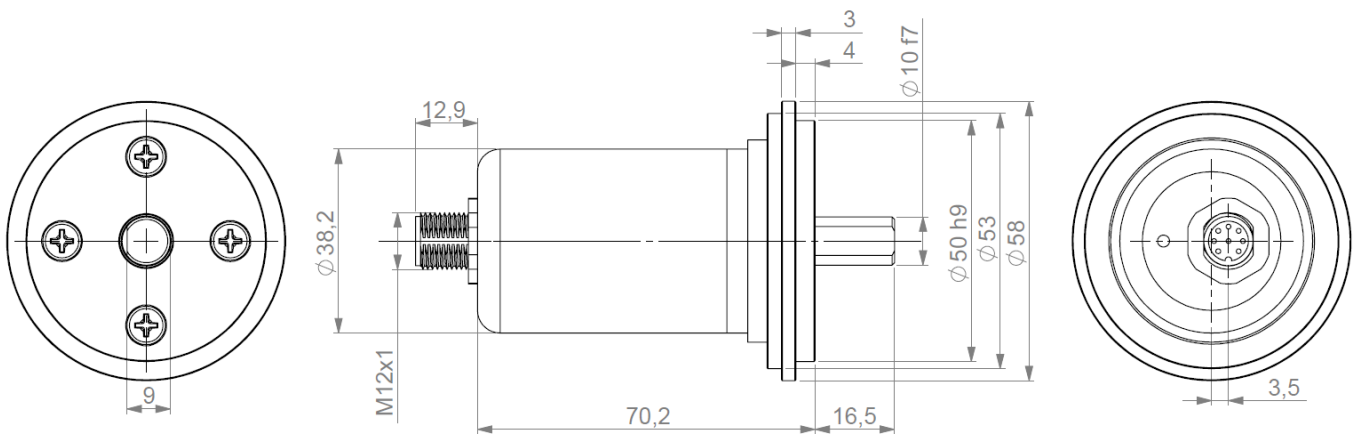

MECHANICAL CHARACTERISTICS

Material	Cover : stainless steel	Vibrations (EN 60068-2-6)	≤ 30 g (10Hz... 1 000Hz)		
	Body : stainless steel	Weight	350 g		
	Shaft: stainless steel	Operating temperature	$-30 \dots +85^{\circ}\text{C}$		
Max. shaft loading	Axial : 270 N	Storage temperature	$-30 \dots +85^{\circ}\text{C}$		
	Radial : 270 N	Humidity	98 % without condensation		
Shaft Inertia	≤ 30 g.cm ²	Protection class (EN 60529)	IP 69K		
Torque	≤ 3 N.cm	Lifetime in 10^8 revolutions with F_a / F_r (axial / radial)			
RPM (continuous operation)	12 000 rpm	100 N / 100 N	270 N / 270 N	300 N / 300 N	
Shock (EN 60068-2-27)	≤ 300 g (half-sine, 6 ms)	200	10	7.6	
Shock (EN 60028-2-29)	≤ 30 g (half-sine, 16ms)				

MAGNETIC ENCODERS - ANALOG ABSOLUTE SINGLE TURN - AXM4 RANGE



ELECTRICAL CHARACTERISTICS

Single turn technology	Magnetic 2 axis Hall sensor	Turn on time	< 1 s
Resolution of output	Max 12 bits over entire measuring range	Current consumption	Typical: 50mA
Single turn accuracy	+/- 0,35°	Electrical life-time	> 10 ⁵ h
Linearity	0.15 %	EMC	EN 61000-6-4 EN 61000-6-2
Supply voltage	12 – 30Vdc	Load resistance	Current: <500Ohms
Cycle period	< 600 µs		Voltage: >10kOhms

ANALOG CONNECTION

Reference	Type	1	2	3	4	5	Ground
00	M12 5 pinouts	Analog output	+Vcc	GND	SET 2	SET 1	Connector body

INPUTS

Set 2	Set 1	Function
0 (N.C. or GND)	0 (N.C. or GND)	Normal operation
0 (N.C. or GND)	1 (> 12Vdc)	Preset zero point (non turning shaft)
1 (> 12Vdc)	0 (N.C. or GND)	Preset max point (non turning shaft)
1 (> 12Vdc)	1 (> 12Vdc)	Pdefault scale (non turning shaft)

ORDERING REFERENCE

AXM4S	10	/	AA	/	5	L3	0	//	00	//	00A	//	**00**
Absolute singleturn encoder	Solid shaft Ø10mm		Stainless steel & IP69K		Supply : 12 to 30Vdc	L3 : 4-20mA L4 : 0-20mA L1 : 0-10Vdc	Programmable encoder		Single turn encoder		Axial M12 5 pinouts		Stainless steel servo flange

Datasheets provided by Sensata Technologies, Inc., its subsidiaries and/or affiliates (“Sensata”) are solely intended to assist third parties (“Buyers”) who are developing systems that incorporate Sensata products (also referred to herein as “components”). Buyer understands and agrees that Buyer remains responsible for using its independent analysis, valuation, and judgment in designing Buyer’s systems and products. Sensata datasheets have been created using standard laboratory conditions and engineering practices. Sensata has not conducted any testing other than that specifically described in the published documentation for a particular datasheet. Sensata may make corrections, enhancements, improvements, and other changes to its datasheets or components without notice.

Buyers are authorized to use Sensata datasheets with the Sensata component(s) identified in each particular datasheet. HOWEVER, NO OTHER LICENSE, EXPRESS OR IMPLIED, BY ESTOPPEL OR OTHERWISE TO ANY OTHER SENSATA INTELLECTUAL PROPERTY RIGHT, AND NO LICENSE TO ANY THIRD PARTY TECHNOLOGY OR INTELLECTUAL PROPERTY RIGHT, IS GRANTED HEREIN. SENSATA DATASHEETS ARE PROVIDED “AS IS”. SENSATA MAKES NO WARRANTIES OR REPRESENTATIONS WITH REGARD TO THE DATASHEETS OR USE OF THE DATASHEETS, EXPRESS, IMPLIED, OR STATUTORY, INCLUDING ACCURACY OR COMPLETENESS. SENSATA DISCLAIMS ANY WARRANTY OF TITLE AND ANY IMPLIED WARRANTIES OF MERCHANTABILITY, FITNESS FOR A PARTICULAR PURPOSE, QUIET ENJOYMENT, QUIET POSSESSION, AND NON-INFRINGEMENT OF ANY THIRD PARTY INTELLECTUAL PROPERTY RIGHTS WITH REGARD TO SENSATA DATASHEETS OR USE THEREOF.

All products are sold subject to Sensata’s terms and conditions of sale supplied at www.sensata.com. SENSATA ASSUMES NO LIABILITY FOR APPLICATIONS ASSISTANCE OR THE DESIGN OF BUYERS’ PRODUCTS. BUYER ACKNOWLEDGES AND AGREES THAT IT IS SOLELY RESPONSIBLE FOR COMPLIANCE WITH ALL LEGAL, REGULATORY, AND SAFETY-RELATED REQUIREMENTS CONCERNING ITS PRODUCTS, AND ANY USE OF SENSATA COMPONENTS IN ITS APPLICATIONS, NOTWITHSTANDING ANY APPLICATIONS-RELATED INFORMATION OR SUPPORT THAT MAY BE PROVIDED BY SENSATA.

Mailing Address: Sensata Technologies, Inc., 529 Pleasant Street, Attleboro, MA 02703, USA

CONTACT US

Regional head offices:

United States of America

Sensata Technologies

Attleboro, MA

Phone: 508-236-3800

E-mail: support@sensata.com

Netherlands

Sensata Technologies Holland B.V.

Hengelo

Phone: +31 74 357 8000

E-mail: support@sensata.com

China

Sensata Technologies China Co., Ltd.

Shanghai

Phone: +8621 2306 1500

E-mail: support@sensata.com

Copyright © 2023 Sensata Technologies, Inc.