

MX15 Series— Modular Incremental Rotary Optical Encoder

BEI Sensors



By the time you have read this first sentence, you could have installed BEI's model MX15 INSTA-MOUNT™ modular optical encoder. In addition to its quick and easy installation, the MX15 is designed to operate with jitter-free output signals without tight controls on shaft endplay, runout or perpendicularity. The new INSTA-MOUNT™ encoder is capable of operating within a temperature range of -10° to +70°C, requiring less than 30 milliamps of L.E.D. current, without degradation of output signals and is short circuit protected. The MX15 is perfectly suited for motor manufacturers and other high volume OEMs.

BEI's INSTA-MOUNT™ Series encoder offers 5V TTL compatible quadrature outputs with index and complements as options. Axial shaft movements during operation, of ±0.010", will not adversely affect the output signals. Shaft run outs of 0.005" TIR can also be absorbed by this device without affecting output signal performance.

Mechanical Specifications

Dimensions: See Figure 1
Weight: 2.0 oz.
Moment of Inertia: 2.6 x 10⁻⁵oz in sec²
Bore Size: see "Ordering Options"

Motor Interface

Mount Holes: #2-56 threads @ 180° on 1.280 dia. B.C.
Mount Hardware: #2-56 x 3/4 in. (provided)
Perpendicularity Shaft to Mount: ±0.0002" TIR
Shaft Runout: 0.005" max (each 0.0001 degrades accuracy by 0.5 arc minutes)
Shaft Endplay Dynamic or Static: ±0.005"
Shaft Finish: 16 micro inches or better. End must be chamfered or rounded
Shaft Tolerance: 0.0002"/-0.0007" (e.g. Ø32493/.2498)
Shaft Length: 0.45" minimum remove (remove cover button for motor through-shafts)

Electrical Specifications

Code: Incremental
Pulses per revolutions (PPR): See "Ordering Options"
Index Pulse Options ungated index (U)
 gated index (G)
Supply Voltage: 5 volts ±5% @ 80mA max.
Output Format: dual channel quadrature & index (MX152 & 153) (no index on MX152)
 (MX156) dual channel quad & index w/ comps
Output Type:
 (MX152 & 153): square wave TTL. 16mA sink
 500ΩA source. Short circuit protected
 (MX156): TTL differential line driver (26LS31 or equiv.) should be terminated into a line receiver (26LS32, or equivalent circuit)
Frequency Response: see graph: Fig 3
Rise Time: 1.0μ sec. max.

Environmental Specifications

Temperature:
 Operating: -10°C to +70°C
 Storage: -40°C to +125°C
Enclosure: unsealed housing units must be protected from harsh environments

Termination Specifications

Terminal Board (Header):
 (MX152 & 153): See Pinout MX152 & 153
 (MX156): See Pinout MX156
Round Shielded Cable:
 (MX152 & 153): See Color Code MX152 & 153
 (MX156): See Color Code MX156

MX15 Series Encoder Ordering Options: for assistance, call 800.350.2727

Use this diagram, working from left to right to construct your model number (example: **MX153-25-500-G-C18**)

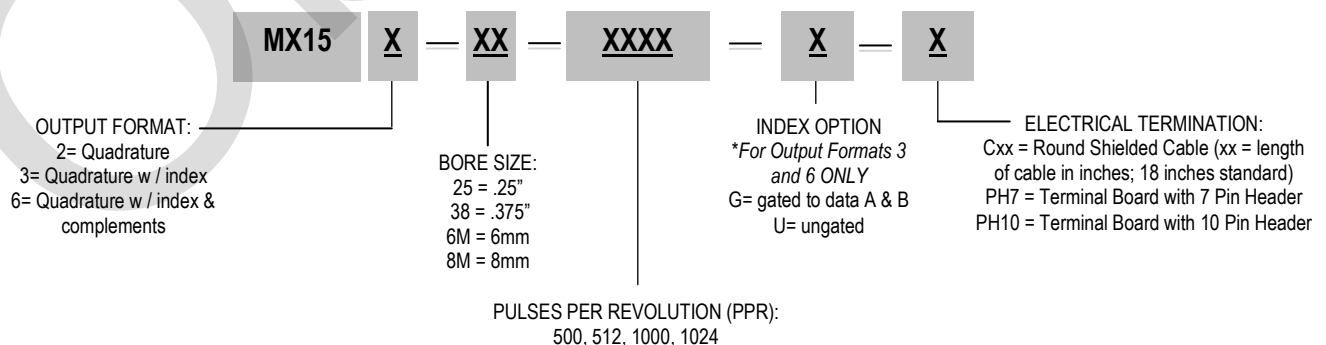

MX15 Series— Modular Incremental Rotary Optical Encoder

BEI Sensors

Dimensions

Figure 1

(MX152/MX153)

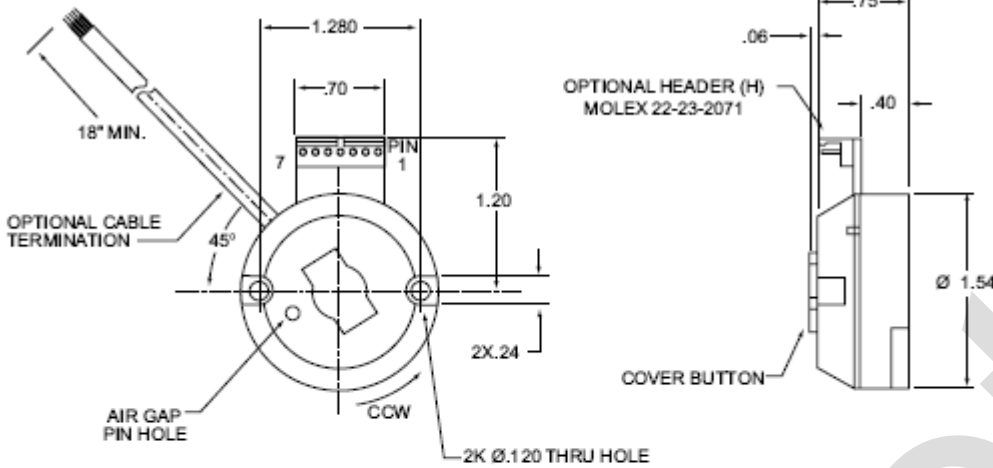
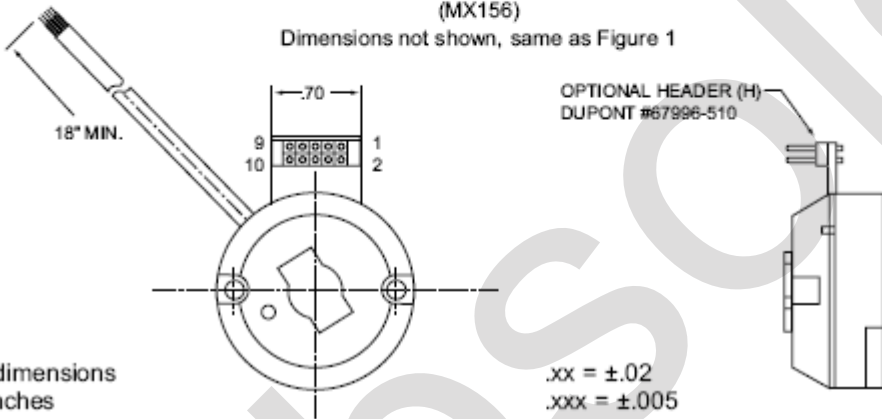

Figure 2

(MX156)

Dimensions not shown, same as Figure 1



Output

Waveform

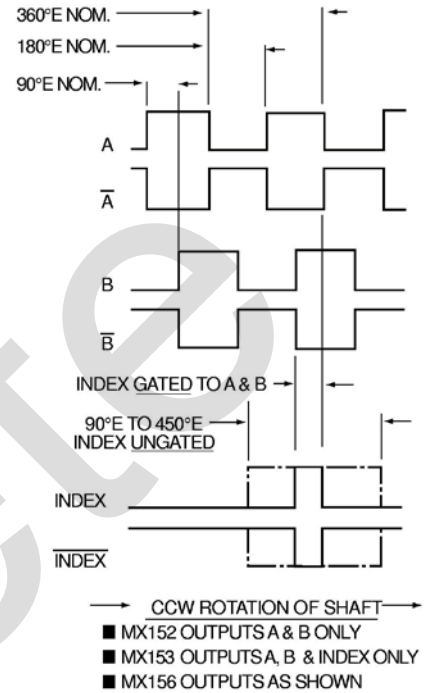
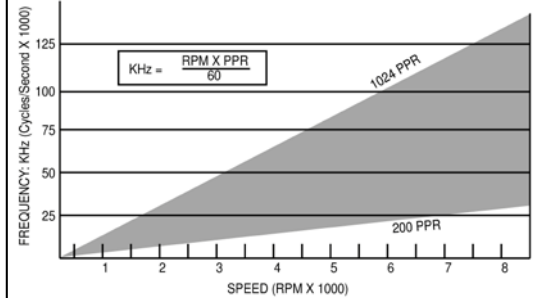

Figure 3



Terminations

Terminal Board (Header)

PINOUT: MX152 & MX153

Pin #	Signal	Pin #	Signal
1	NC	5	Data B
2	Index (MX153)	6	Data A
3	NC	7	ground
4	+5 volt		

PINOUT: MX156

Pin #	Signal	Pin #	Signal
1	+5 volt	6	Data Ā
2	+5 volts	7	Ground
3	Index	8	Ground
4	Index	9	Data B
5	Data A	10	Data B̄

Round Shielded Cable

COLOR CODE: MX152 & MX153

Color	Function	Color	Function
Red	+5 volt	Green	Data B
Black	Ground	Orange	Index(MX153)
White	Data A		

COLOR CODE: MX156

Color	Function	Color	Function
Red	+5 volt	Green	Data B
Black	Ground	Wht/Blk	Data B
White	Data A	Orange	Index
Blue	Data A	Red/Blk	Index

Installation Instructions for MX15 Series Encoders

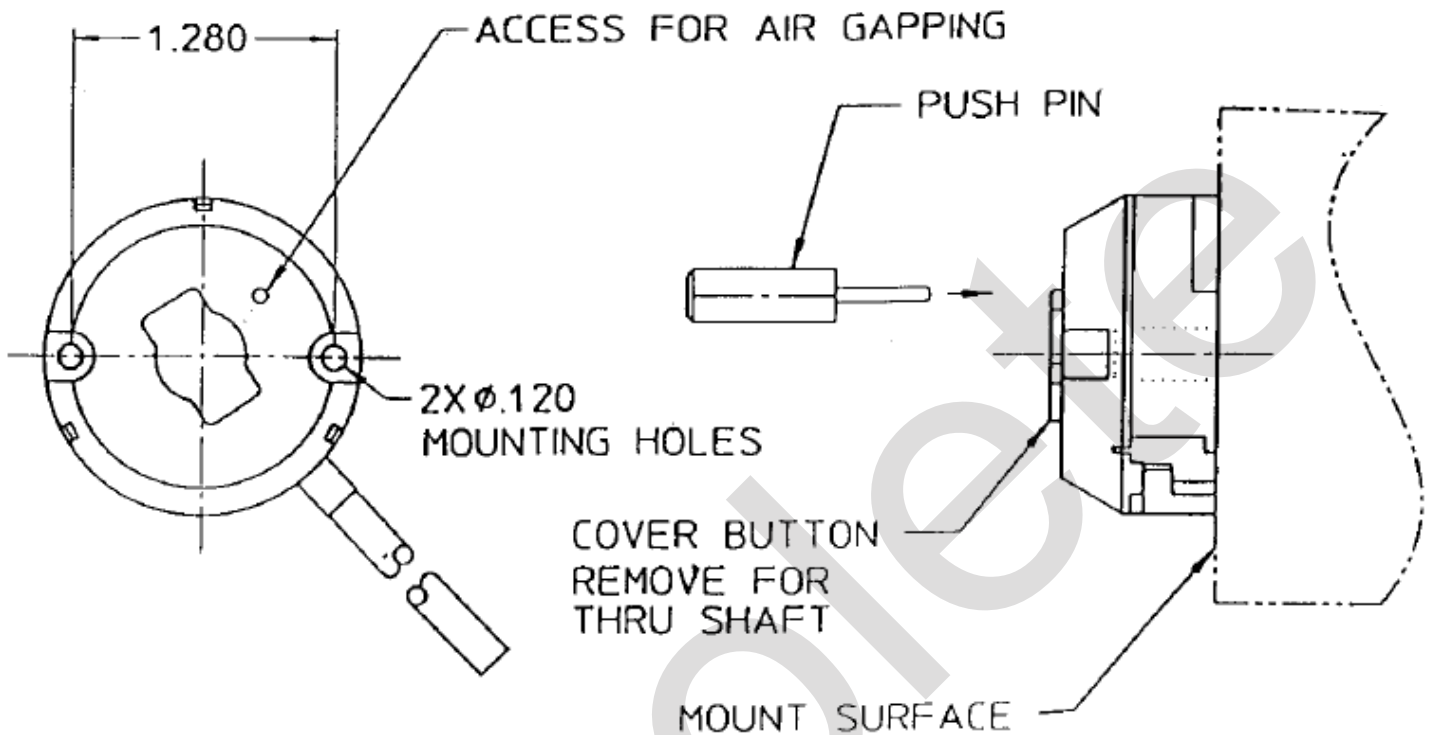

Preparation:

1. Inspect motor interface per MX15 Data Sheet or specification drawing.
2. Motor shaft must be free of burrs and other surface defects.

Installation:

1. Motor shaft should NOT be rotating during initial encoder installation.
2. Hold encoder perpendicular to motor shaft. Guide the encoder onto the motor shaft, pushing encoder STRAIGHT on until it is flush against the motor surface. Do NOT rock side to side.
3. Install two #2-56 mount screws. Do not fully tighten at this point. (Note: A thread sealant should be applied to the screw threads.)
4. Rotate the motor shaft (300 RPM, minimum). Insert push pin into the 1/16 hole in top of encoder and press until pin bottoms out on encoder cover momentarily, then remove pin. CAUTION: DO NOT press the push pin while motor shaft is stationary. Pin should only be pressed for one or two seconds while shaft is rotating.
5. Fully tighten mounting screws. (recommended torque is 20 to 25 ounce inches.)
6. This completes the mechanical installation. Proceed with electrical connections as indicated on product data sheet or specification drawing.

Removal:

1. Motor shaft may be stationary or rotating up to 1000 RPM during encoder removal.
2. Remove two mounting screws.
3. Grasp encoder firmly and pull STRAIGHT off the motor shaft. Do NOT rock side to side.

These commodities, technology or software if exported from the United States must be in accordance with the Bureau of Industry, and Security, Export Administration regulations. Diversion contrary to U.S law is prohibited.

Datasheets provided by Sensata Technologies, Inc., its subsidiaries and/or affiliates (“Sensata”) are solely intended to assist third parties (“Buyers”) who are developing systems that incorporate Sensata products (also referred to herein as “components”). Buyer understands and agrees that Buyer remains responsible for using its independent analysis, valuation, and judgment in designing Buyer’s systems and products. Sensata datasheets have been created using standard laboratory conditions and engineering practices. Sensata has not conducted any testing other than that specifically described in the published documentation for a particular datasheet. Sensata may make corrections, enhancements, improvements, and other changes to its datasheets or components without notice.

Buyers are authorized to use Sensata datasheets with the Sensata component(s) identified in each particular datasheet. HOWEVER, NO OTHER LICENSE, EXPRESS OR IMPLIED, BY ESTOPPEL OR OTHERWISE TO ANY OTHER SENSATA INTELLECTUAL PROPERTY RIGHT, AND NO LICENSE TO ANY THIRD PARTY TECHNOLOGY OR INTELLECTUAL PROPERTY RIGHT, IS GRANTED HEREIN. SENSATA DATASHEETS ARE PROVIDED “AS IS”. SENSATA MAKES NO WARRANTIES OR REPRESENTATIONS WITH REGARD TO THE DATASHEETS OR USE OF THE DATASHEETS, EXPRESS, IMPLIED, OR STATUTORY, INCLUDING ACCURACY OR COMPLETENESS. SENSATA DISCLAIMS ANY WARRANTY OF TITLE AND ANY IMPLIED WARRANTIES OF MERCHANTABILITY, FITNESS FOR A PARTICULAR PURPOSE, QUIET ENJOYMENT, QUIET POSSESSION, AND NON-INFRINGEMENT OF ANY THIRD PARTY INTELLECTUAL PROPERTY RIGHTS WITH REGARD TO SENSATA DATASHEETS OR USE THEREOF.

All products are sold subject to Sensata’s terms and conditions of sale supplied at www.sensata.com. SENSATA ASSUMES NO LIABILITY FOR APPLICATIONS ASSISTANCE OR THE DESIGN OF BUYERS’ PRODUCTS. BUYER ACKNOWLEDGES AND AGREES THAT IT IS SOLELY RESPONSIBLE FOR COMPLIANCE WITH ALL LEGAL, REGULATORY, AND SAFETY-RELATED REQUIREMENTS CONCERNING ITS PRODUCTS, AND ANY USE OF SENSATA COMPONENTS IN ITS APPLICATIONS, NOTWITHSTANDING ANY APPLICATIONS-RELATED INFORMATION OR SUPPORT THAT MAY BE PROVIDED BY SENSATA.

Mailing Address: Sensata Technologies, Inc., 529 Pleasant Street, Attleboro, MA 02703, USA

CONTACT US

Regional head offices:

United States of America

Sensata Technologies

Attleboro, MA

Phone: 508-236-3800

E-mail: support@sensata.com

Netherlands

Sensata Technologies Holland B.V.

Hengelo

Phone: +31 74 357 8000

E-mail: support@sensata.com

China

Sensata Technologies China Co., Ltd.

Shanghai

Phone: +8621 2306 1500

E-mail: support@sensata.com

Copyright © 2023 Sensata Technologies, Inc.