

Property of
Sensata Technologies

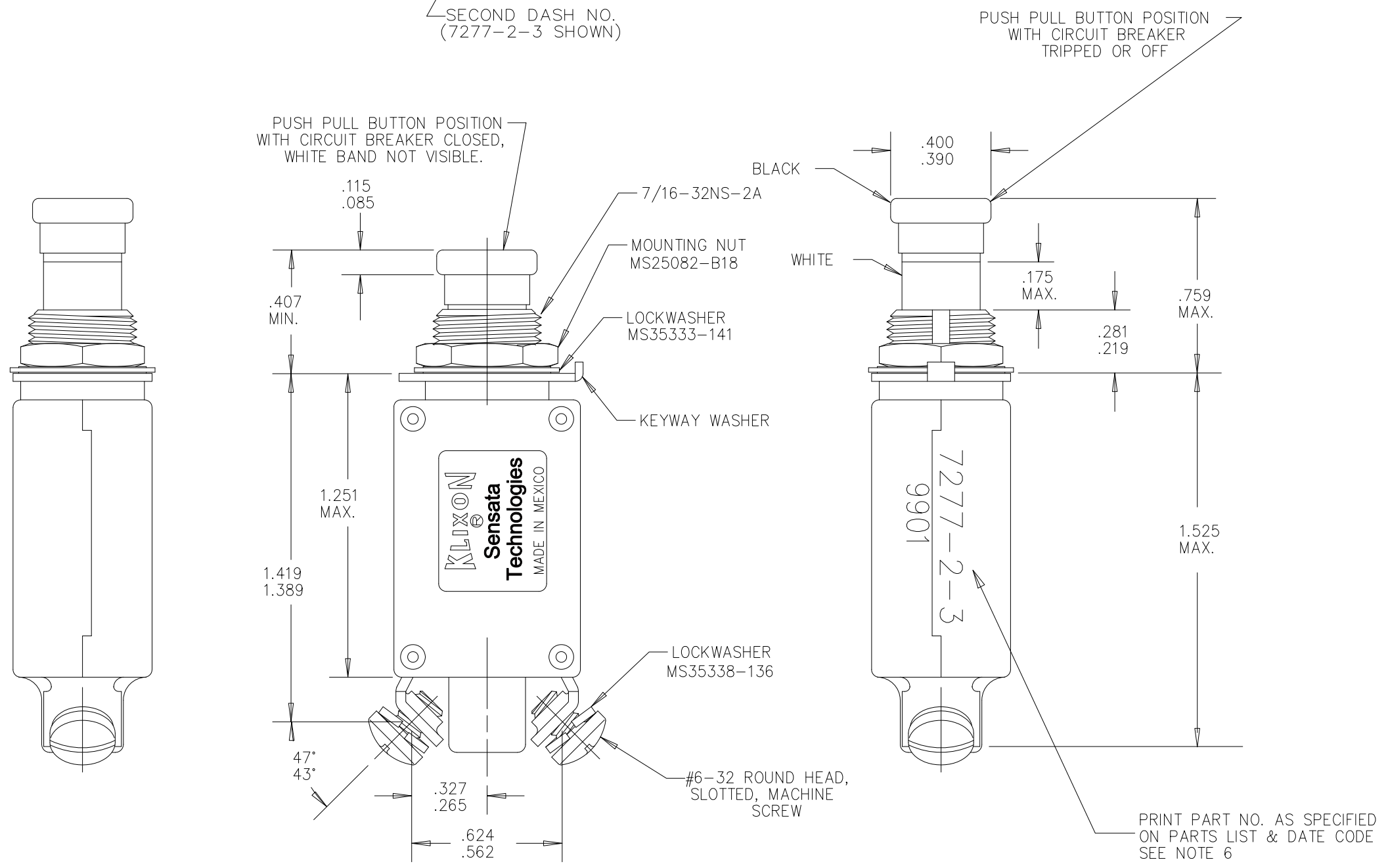
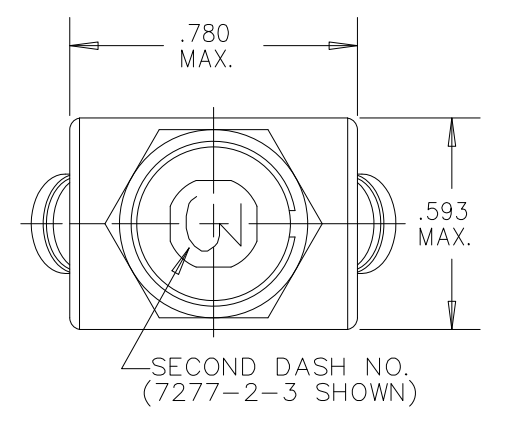
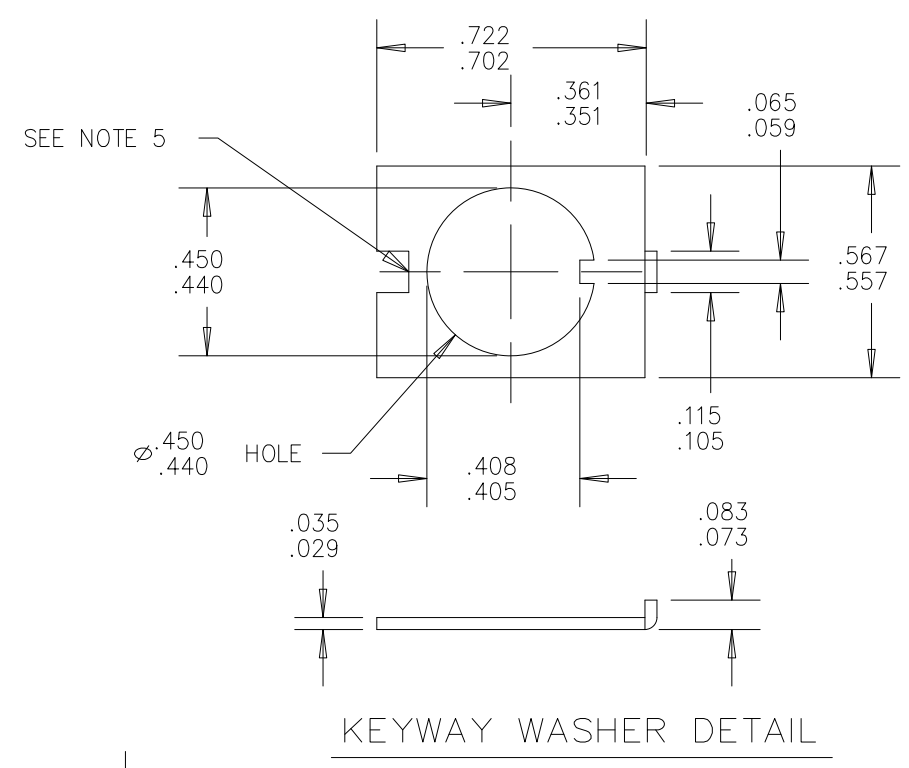

ZONE	REV.	REVISION DESCRIPTION	ECN NO.	DATE
B2	P	ADDED 7277-2-25 PART NO.; 7277-2-15 & 7277-2-20, CURRENT INTERRUPTING CAPACITY FOR 28 VDC WAS "2000 AMPS"; CHANGED MAXIMUM VOLTAGE DROP FOR THE FOLLOWING: 7277-2-2 WAS 0.70, 7277-2-2 1/2 WAS 0.50, 7277-2-3 WAS 0.33, 7277-2-4 WAS 0.30, 7277-2-5 WAS 0.25, 7277-2-7 1/2 WAS 0.20, 7277-2-10, -2-15 & -2-20 WAS 0.15; REMOVED "1/2 AMP THRU 10 AMP" FROM "CALIBRATION:" GML	ECO-059939	04-NOV-2010
C2				

PERFORMANCE CHARACTERISTICS (DETAIL PERFORMANCE PER MIL-C-5809)

- OVERLOAD CYCLING ----- 100 CYCLES AT 200% RATING
- VIBRATION ----- 10 G'S 50-500 HZ
- MECHANICAL SHOCK ----- 35 G'S AT 11.5 MILLISECOND DURATION
- ACCELERATION ----- 10 G'S MINIMUM
- SAND AND DUST ----- 12 HOURS
- CORROSION ----- SALT SPRAY 50 HOURS
- HUMIDITY ----- 10 DAYS
- EXPLOSION PROOF ----- WHILE INTERRUPTING RUPTURE CURRENTS

- ENDURANCE:
- 120 VAC ----- 400 HZ INDUCTIVE ----- 2500 CYCLES
 - RESISTIVE ----- 5000 CYCLES
 - 30 VDC ----- INDUCTIVE ----- 2500 CYCLES
 - RESISTIVE ----- 5000 CYCLES
 - MECHANICAL ----- 5000 CYCLES

CALIBRATION:

AMBIENT TEMP.	MIN.ULT.TRIP	MAX.ULT.TRIP	200%	500%	1000%
+25°C	110% RATING	150% RATING	2-35 SEC.	.15-1.7 SEC.	.028-.55 SEC.

PART NO.	AMP RATING	MAXIMUM VOLTAGE DROP	CURRENT INTERRUPTING CAPACITY	
			120 VAC, 400 HZ	28 VDC
7277-2-1/2	1/2	2.00	UNLIMITED	UNLIMITED
7277-2-3/4	3/4	1.45	UNLIMITED	UNLIMITED
7277-2-1	1	1.10	UNLIMITED	UNLIMITED
7277-2-1 1/2	1 1/2	0.75	UNLIMITED	UNLIMITED
7277-2-2	2	0.75	800 AMPS	UNLIMITED
7277-2-2 1/2	2 1/2	0.70	800 AMPS	UNLIMITED
7277-2-3	3	0.55	800 AMPS	UNLIMITED
7277-2-4	4	0.45	800 AMPS	UNLIMITED
7277-2-5	5	0.35	800 AMPS	UNLIMITED
7277-2-7 1/2	7 1/2	0.30	500 AMPS	2000 AMPS
7277-2-10	10	0.28	500 AMPS	2000 AMPS
7277-2-15	15	0.25	500 AMPS	800 AMPS
7277-2-20	20	0.25	500 AMPS	800 AMPS
7277-2-25	25	0.25	500 AMPS	800 AMPS

NOTES:

- ALL MOUNTING HARDWARE HAS A DULL BLACK FINISH.
- CIRCUIT BREAKERS ARE SUITABLE FOR MOUNTING IN A 1/8" THICK PANEL OR LESS.
- WEIGHT ACTUAL: 25 GRAMS
- EPOXY SURFACES ARE NON-DIMENSIONED. ENVELOPE DRAWING DIMENSIONS DO NOT APPLY TO THESE PROJECTED EPOXY SURFACES.
- NON FUNCTIONAL NOTCH ON THE BACK OF THE KEYWAY WASHER IS OPTIONAL.
- DATE CODE SPEC: 10588-285.

FOR REFERENCE ONLY, CHECK LATEST REVISION BEFORE USE. PARTS MADE TO THIS PRINT MUST CONFORM TO E9898 REV. E		529 PLEASANT STREET P.O. BOX 2964 ATTLEBORO, MA 02703	
DRAWN CHAS. FLEURANT DATE 30-OCT-1991 ENGINEER K.B. GASSER DATE 14-JAN-1992 APPROVED JON PETRIE DATE 19-DEC-1994 APPROVED DATE	SENSATA TECHNOLOGIES PROPRIETARY AND CONFIDENTIAL. NEITHER THIS PRINT NOR THE INFORMATION CONTAINED HEREON IS TO BE USED AGAINST THE INTERESTS OF SENSATA TECHNOLOGIES OR AGAINST THE INTERESTS OF ANY OF ITS AFFILIATED COMPANIES OR WHOLLY OWNED SUBSIDIARIES. INTERPRET DIMENSIONING AND TOLERANCING PER ASME Y14.5-2009, UNLESS OTHERWISE SPECIFIED DIMENSIONS ARE IN INCHES. TOLERANCES DECIMALS ANGLES	TITLE 7277-2 TYPE PUSH-PULL TRIP FREE CIRCUIT BREAKER ENVELOPE DRAWING SIZE DWG NO. 7277-2 REV. P SCALE 1:1 AUTOCAD SHEET 1 OF 1	