

PART NO: LBKS02
 2 AXIS LATHE BRACKET KIT
 FITS 1 SPHEROSYN SERIAL
 & 1 MICROSYN SERIAL ENCODERS
 (USE IN CONJUNCTION WITH ENCODER INSTALL GUIDE 023-82570)

KIT CONTENTS & HOLE DIMESNIIONS

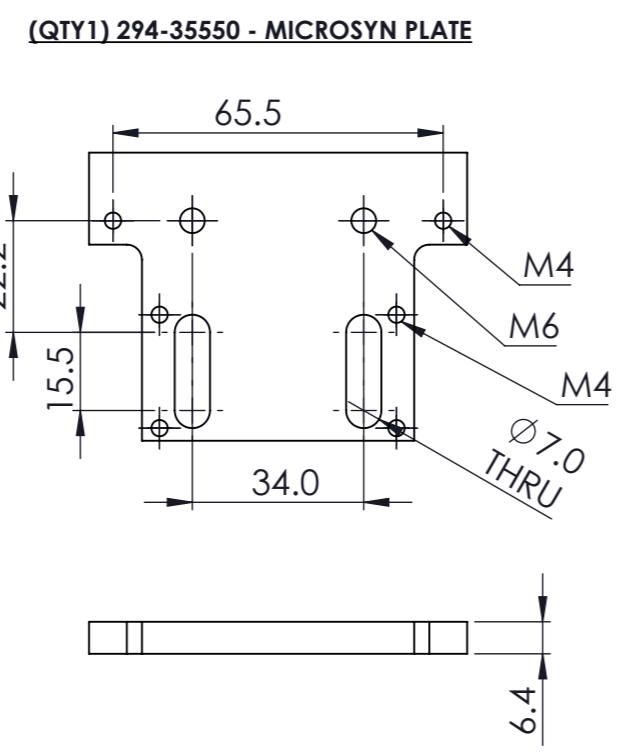
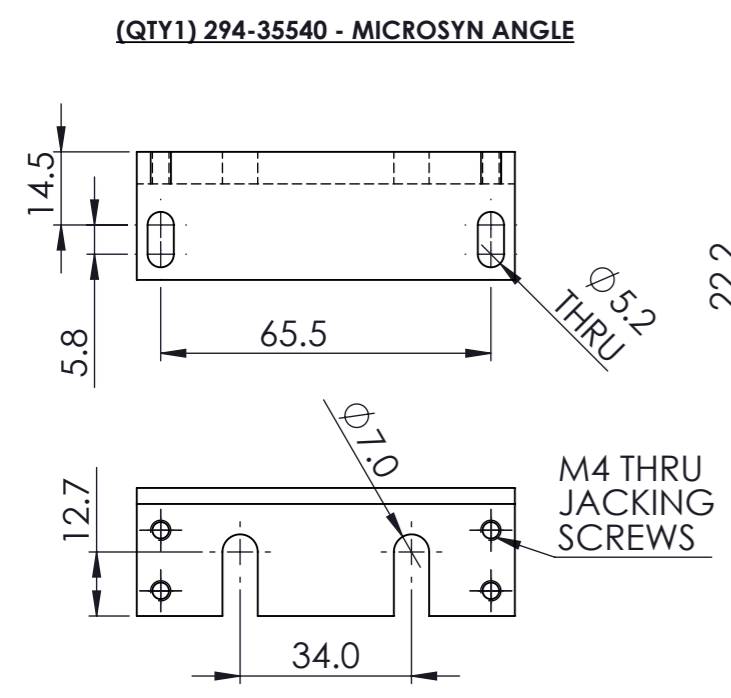
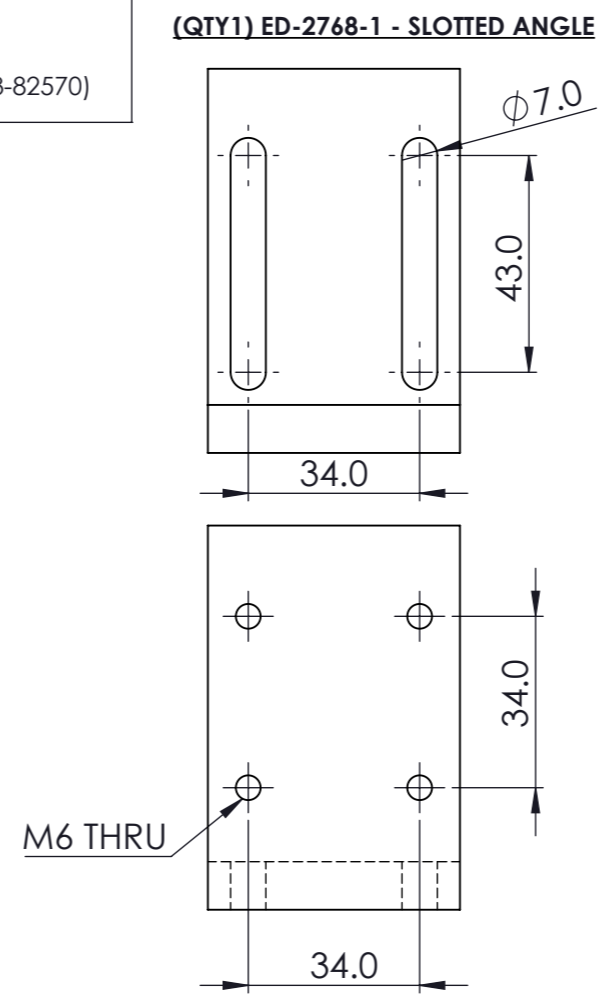
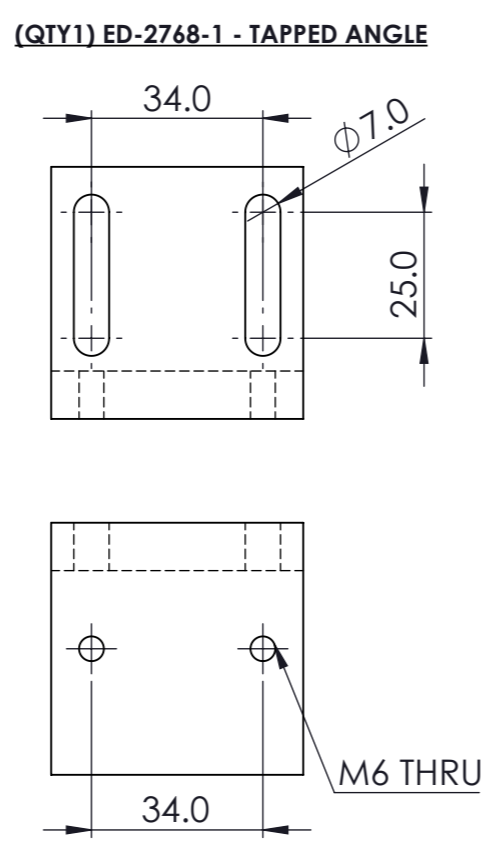
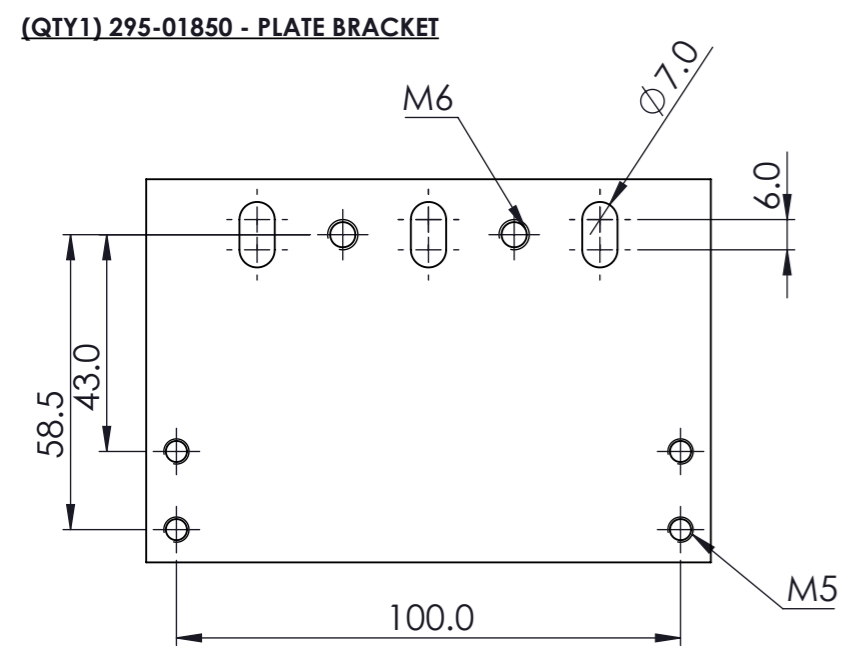

Kit No:	LBKS02	
Description	2 AXIS LATHE KIT 1 X MICROSYN SERIAL, 1 X SPHEROSYN SERIAL	
BOM		
Pt no	Description	Qty
294-35550	MICROSYN FLAT PLATE	1
294-35540	MICROSYN ANGLED BRACKET	1
295-01850	LRG ENCODER MOUNTING PLATE	1
ED-2768/1	TAPPED ANGLE	1
ED-2768/2	LARGE SLOTTED BRACKET	1
ED-2768/10	HD TAPPED ANGLE	1
	M5 x 20 SOC CAP HD SCREW	4
	M6 x 12 SOC CAP HD SCREW	2
	M5 x 30 SOC CAP HD SCREW	2
	M6 FLAT WASHER	10
	M6 x 20 SOC CAP HD SCREW	8
	M6 x 25SOC CAP HD SCREW	2
	M5 FLAT WASHER	2
	M4 x 12 SOC GRUB SCREWS	8
	M4 x 12 SOC CAP HD SCREW	2
	M4 x 25 SOC CAP HD SCREW	2
	M4 FLAT WASHER	2
	M6 X 12 SOC GRUB SCREW	2
SEPERATED KIT IN BLISER PACK AS ON LBK020		1
295-00500	SEM BRACKET	1
	M5 x 16 BUTTON HD SCREW	1
	M5 FLAT WASHER	1
	M3 FLAT WASHER	1
	M3 COIL SPRINT WASHER	1
	M3 X 16 HEX HEAD SCREW	1
	M3 X 8 GRUB SCREW	4
	M6 X 10 SOC BUTTIN HEAD SCREWS	2

REV	DATE	ECO	ALTERATION	CWH
1	21/04/22	N/A	MISC BOM AND DESIGN CHANGES	CWH

TITLE: LBKS02 - BRACKET KIT

DRAWN: C. WHITMORE 21/06/2021

CHECKED:

APPROVED:

MATERIAL:

FINISH:

WEIGHT: 0.21 KG

NOTE: ENSURE: SHARP EDGES AND BORES ARE DEBURRED
 SURFACE FINISH HAS NO BLEMISHES OR SCRATCHES AND PARTS ARE CLEAN

SCALE: N.T.S

TOLERANCES:- 0 DECIMAL PLACES ±0.5
 1 DECIMAL PLACE ±0.2
 2 DECIMAL PLACES ±0.1
 ANGULAR ±1°

STATED:-
 DIMENSIONS ARE IN M.M.
 THREADS ARE METRIC COARSE

SCREWS TO FIX GAURDING INCLUDED WITH SCALE BRACKET KIT GAURDS NOT SHOWN FOR CLARITY

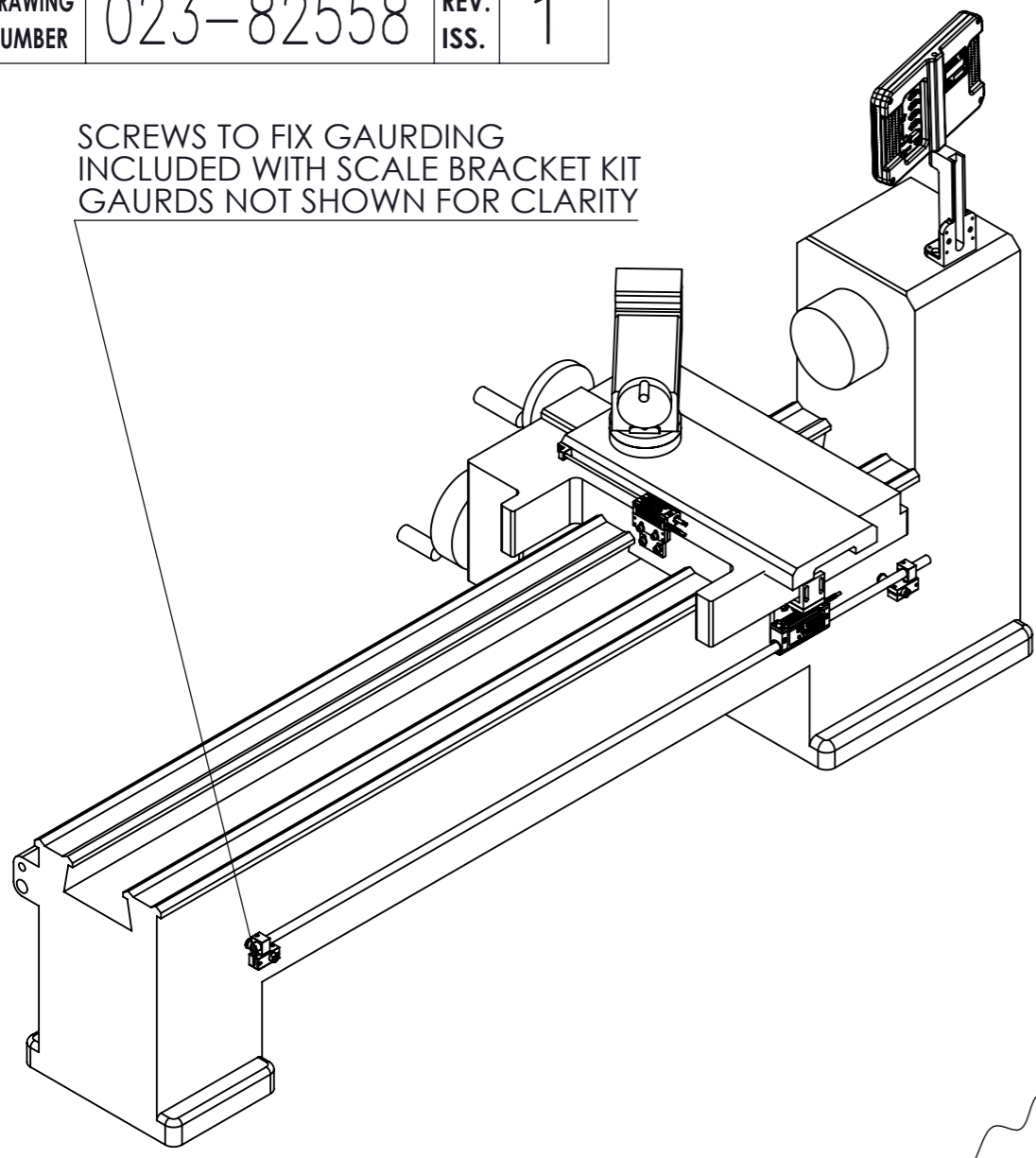

OPTION A

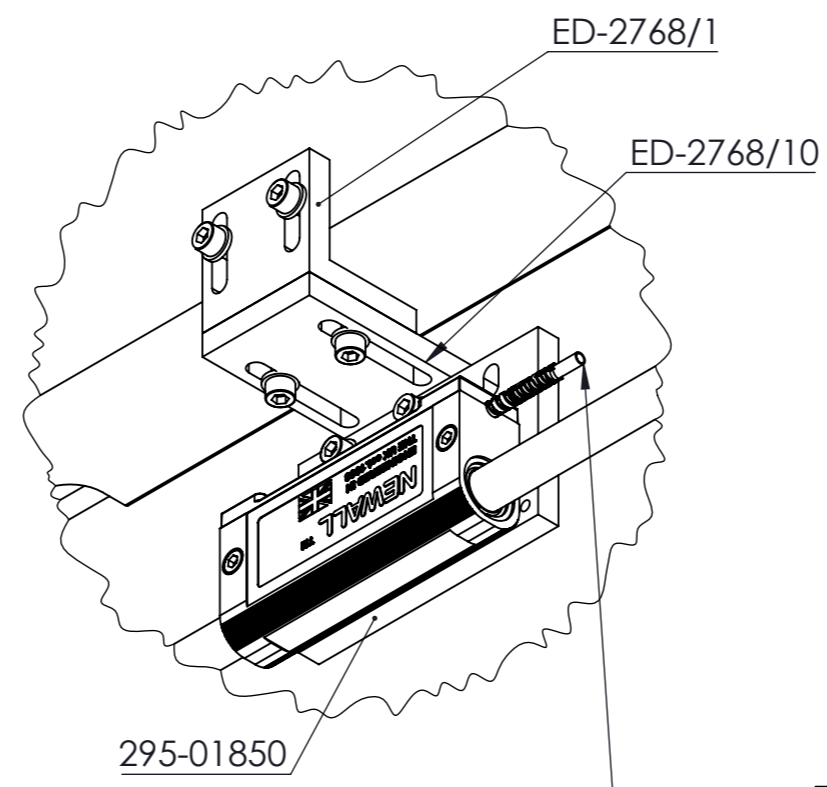

SEE INSTALL MANUAL FOR CABLE ROUTING GUIDANCE

OPTION B

IT IS RECOMENDED, WHERE POSSIBLE 2 PLANES OF ADJUSTMENT ARE USED ON INSTALLATIONS.

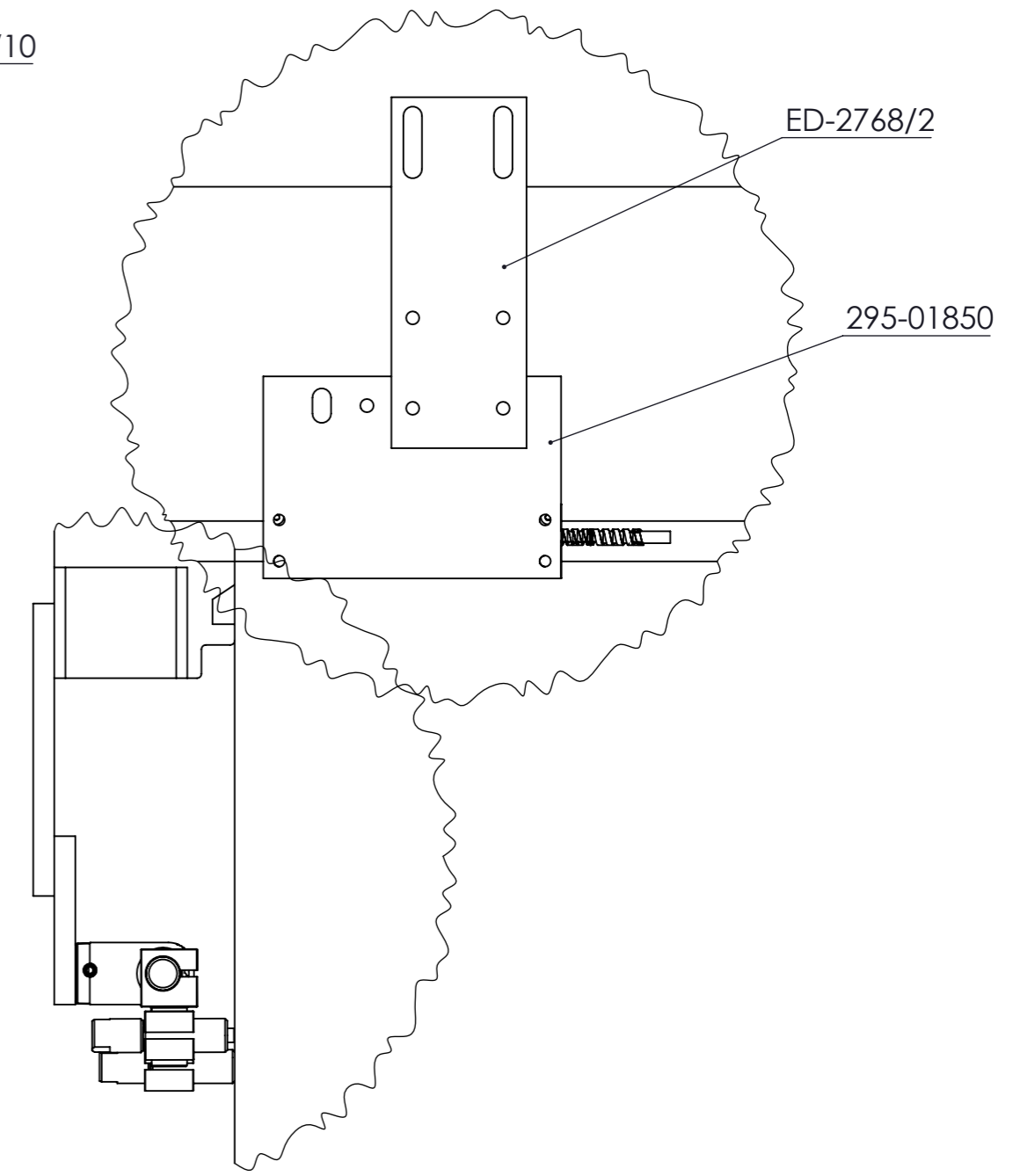

NOTE: OTHER ORIENTATIONS OF MOUNTING POSSIBLE. SOME MODIFICATION OF BRACKETS (DRILLING OUT HOLES) MAY BE REQUIRED

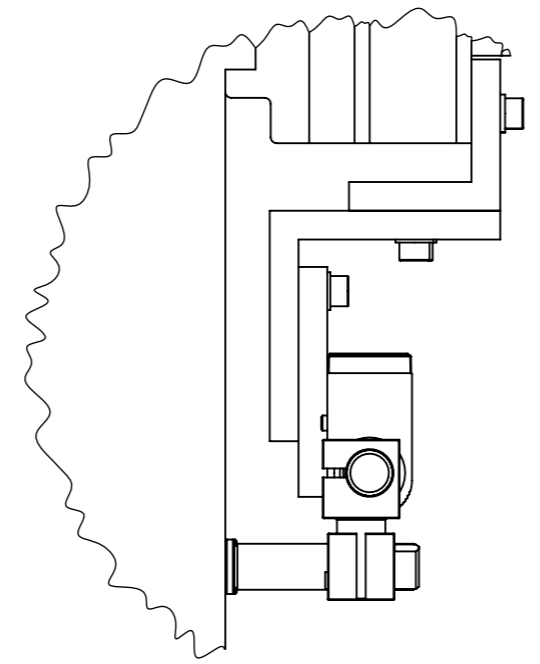

MATERIAL: FINISH: WEIGHT: 0.21 KG NOTE: ENSURE: SHARP EDGES AND BORES ARE DEBURRED SURFACE FINISH HAS NO BLEMISHES OR SCRATCHES AND PARTS ARE CLEAN

					TITLE: LBKS02 - BRACKET KIT	
1	21/04/22	N/A	MISC BOM AND DESIGN CHANGES	CWH	DRAWN: C. WHITMORE	21/06/2021
REV	DATE	ECO	ALTERATION		CHECKED:	
					APPROVED:	

SCALE N.T.S. UNLESS OTHERWISE STATED:- DIMENSIONS ARE IN M.M. TOLERANCES:- 0 DECIMAL PLACES ±0.5 1 DECIMAL PLACE ±0.2 2 DECIMAL PLACES ±0.1 ANGULAR ±1° THREADS ARE METRIC COARSE

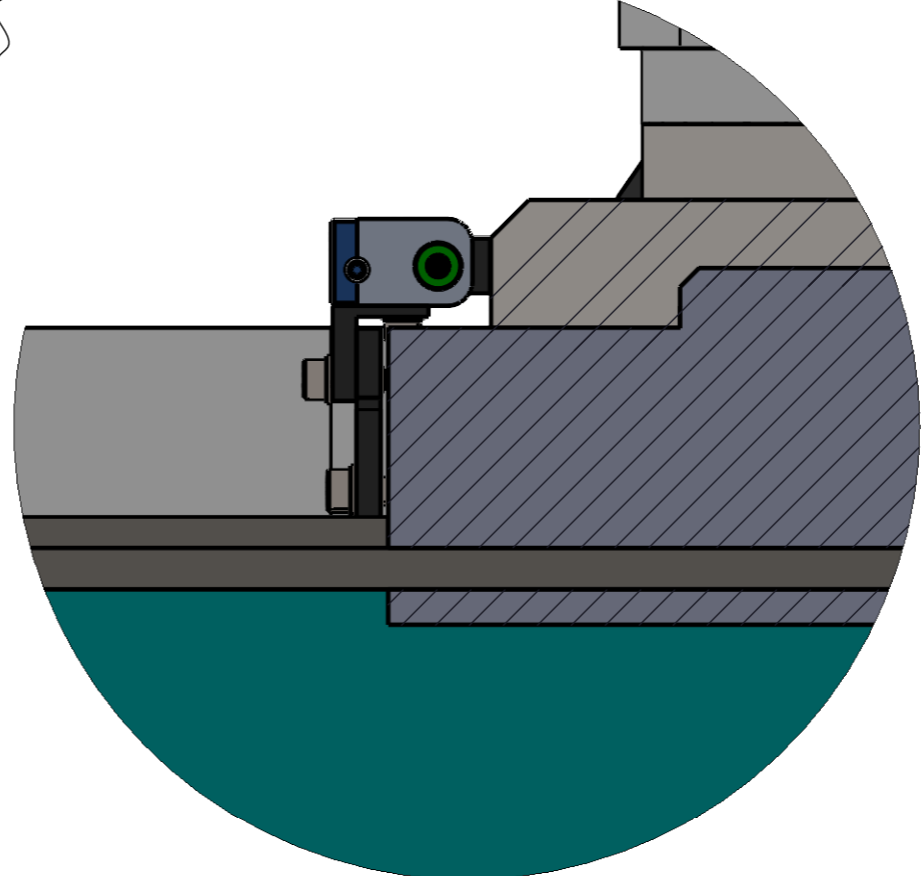
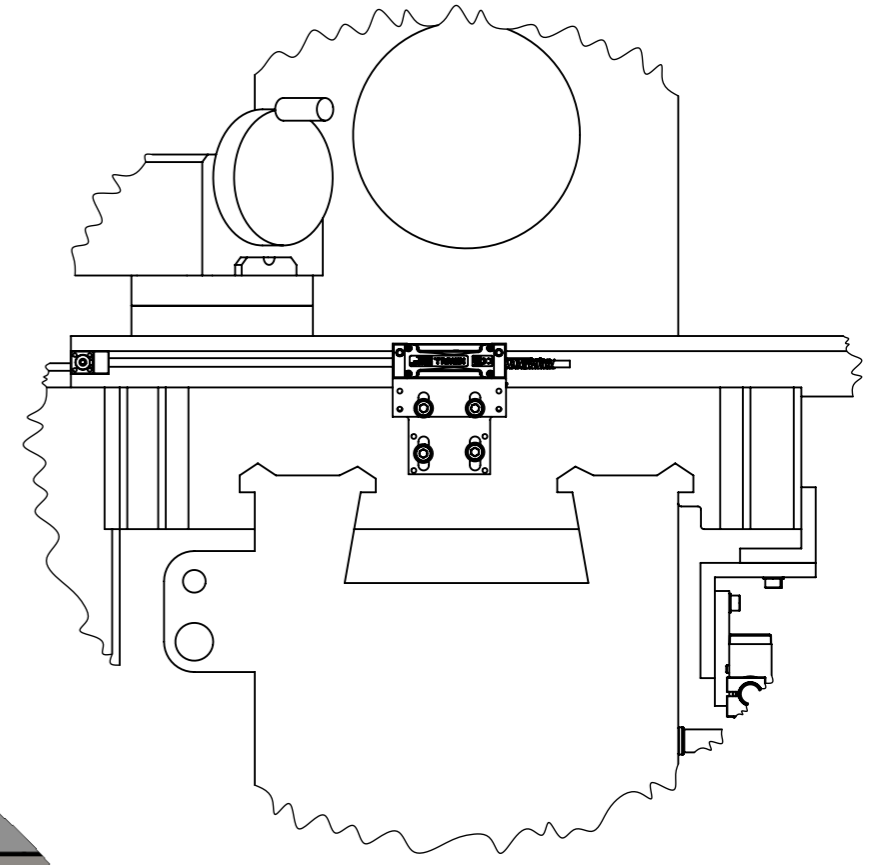
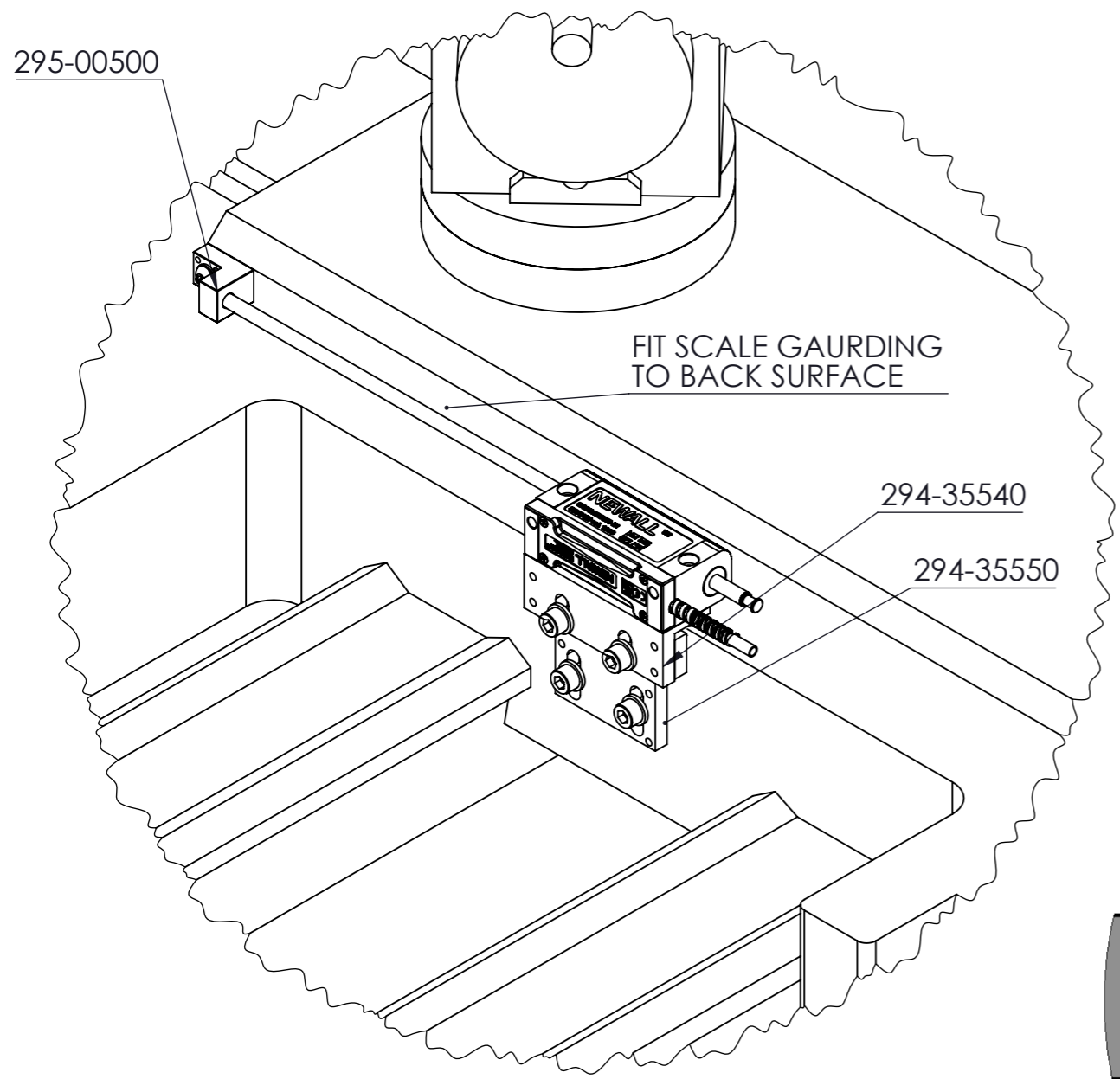

				TITLE: LBKS02 - BRACKET KIT		MATERIAL:		NOTE: ENSURE: SHARP EDGES AND BORES ARE DEBURRED SURFACE FINISH HAS NO BLEMISHES OR SCRATCHES AND PARTS ARE CLEAN					
						FINISH:		SCALE: N.T.S		UNLESS OTHERWISE STATED:- DIMENSIONS ARE IN M.M. THREADS ARE METRIC COARSE		TOLERANCES:- 0 DECIMAL PLACES ±0.5 1 DECIMAL PLACE ±0.2 2 DECIMAL PLACES ±0.1 ANGULAR ±1°	
						WEIGHT: 0.21 KG		SHEET: 3 OF 3		DRAWING NUMBER: 023-82558		REV. ISS.: 1	
REV	DATE	ECO	ALTERATION	DRAWN: C. WHITMORE	21/06/2021	Leicester NEWALL England		THIS DRAWING IS THE PROPERTY OF NEWALL MEASUREMENT SYSTEMS LIMITED. THE INFORMATION THEREON MAY NOT BE COPIED OR USED WITHOUT WRITTEN PERMISSION					