

Property of
Sensata Technologies

ZONE	REV.	REVISION DESCRIPTION	ECN NO.	DATE
C6	U	DIM. 28MAX WAS MEASURED FROM THE BOTTOM OF THE SIDE CART TO THE MOUNTING FACE DT	ECO-116106	12-JUN-2015

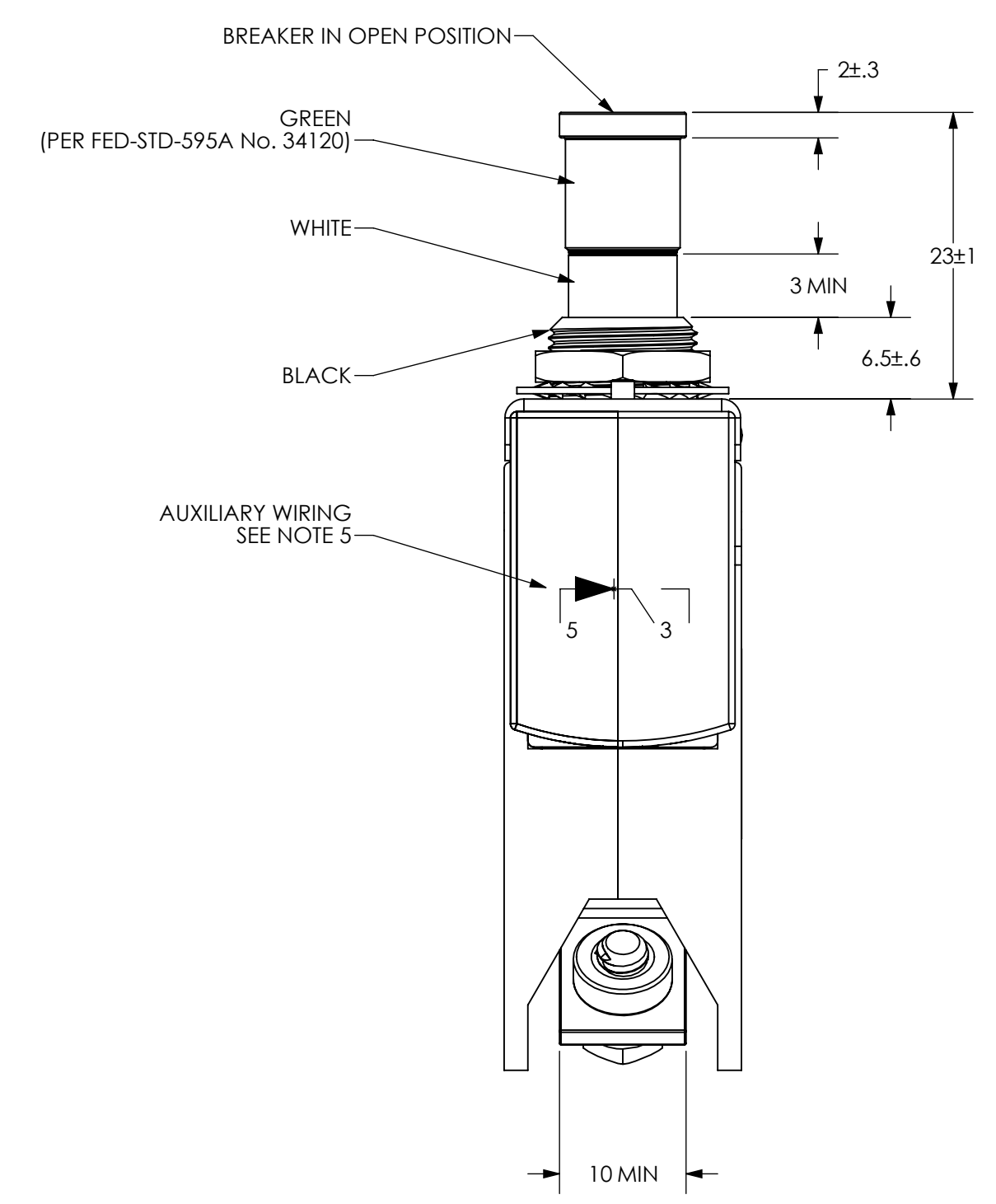
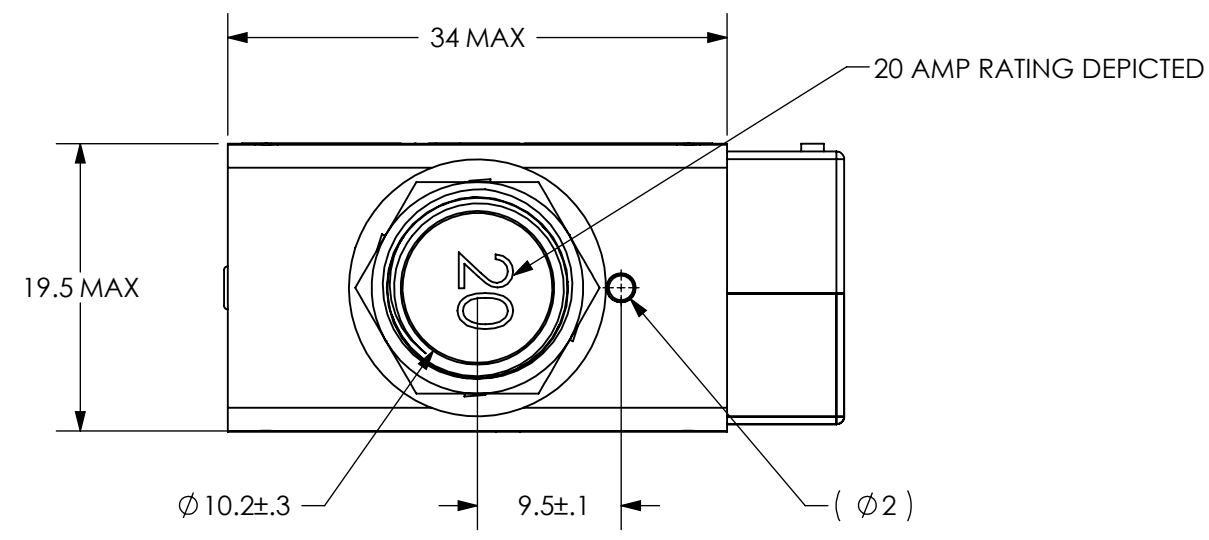

PERFORMANCE CHARACTERISTICS

DETAIL PERFORMANCE PER prEN3661-001 AND prEN3661-006.
 VIBRATION CURVE 'J' OF EUROCAE ED-14B, 3 G'S, 2000 HZ
 MECHANICAL SHOCK 50 G'S
 CORROSION SALT SPRAY 48 HOURS
 HUMIDITY 48 HOURS

ENDURANCE:

115 VAC	360-800 HZ INDUCTIVE	2500 CYCLES
28 VDC	RESISTIVE	2500 CYCLES
	INDUCTIVE	2500 CYCLES
	MECHANICAL	NO LOAD
		5000 CYCLES

CALIBRATION: 20 AMP THRU 60 AMP

	MIN. ULT. TRIP	MAX. ULT. TRIP	200%	500%	1000%
+23°C (+73°F)	110% RATING	145% RATING	2-18 SEC.	0.15-2.5 SEC.	0.045-0.6 SEC.
-55°C (-67°F)	110% RATING	165% RATING	70 SEC. MAX.	0.15-2.5 SEC.	0.045-0.6 SEC.
+70°C (+158°F)	105% RATING	145% RATING	1.5 SEC. MIN.	0.15-2.5 SEC.	0.045-0.6 SEC.
+125°C (+257°F)	90% RATING	145% RATING	1.5 SEC. MIN.	0.15-2.5 SEC.	0.045-0.6 SEC.

RUPTURE:

20 THRU 50 AMP	115VAC, 380-800 HZ 28 VDC	2000 AMPS RMS 4000 AMPS D.C.
60 AMP	115VAC, 380-800 HZ 28 VDC	2000 AMPS RMS 3000 AMPS D.C.

OPERATIONAL FORCES:
 PULLOUT 5 - 45 N (1.1 - 10.1 LBS)
 RESET 8 - 80 N (1.8 - 18.0 LBS)

OPERATING ALTITUDE: 15,000 M (49,200 FT)
 WEIGHT: 75.0 GRAMS MAX. (WITH CONNECTION HARDWARE)

VOLTAGE DROP:

20 AMP	0.150 VOLTS MAX.
25 AMP	0.150 VOLTS MAX.
30 AMP	0.150 VOLTS MAX.
35 AMP	0.150 VOLTS MAX.
40 AMP	0.120 VOLTS MAX.
45 AMP	0.120 VOLTS MAX.
50 AMP	0.120 VOLTS MAX.
60 AMP	0.120 VOLTS MAX.

AUXILIARY SWITCH CHARACTERISTICS:

LOAD TYPE	28 VDC	5 VDC	5 VAC
RESISTIVE	≤ 0.5A ≥ 3 mA	≥ 3 mA	
LAMP	≤ 0.2A		0.23A

SENSATA PART NUMBER	CUSTOMER PART NUMBER WITH TERMINAL HARDWARE	CUSTOMER PART NUMBER WITHOUT TERMINAL HARDWARE
5TC65-20	EN3661-005A20AA	EN3661-005A20AB
5TC65-25	EN3661-005A25AA	EN3661-005A25AB
5TC65-30	EN3661-005A30AA	EN3661-005A30AB
5TC65-35	EN3661-005A35AA	EN3661-005A35AB
5TC65-40	EN3661-005A40AA	EN3661-005A40AB
5TC65-45	EN3661-005A45AA	EN3661-005A45AB
5TC65-50	EN3661-005A50AA	EN3661-005A50AB
5TC65-60		

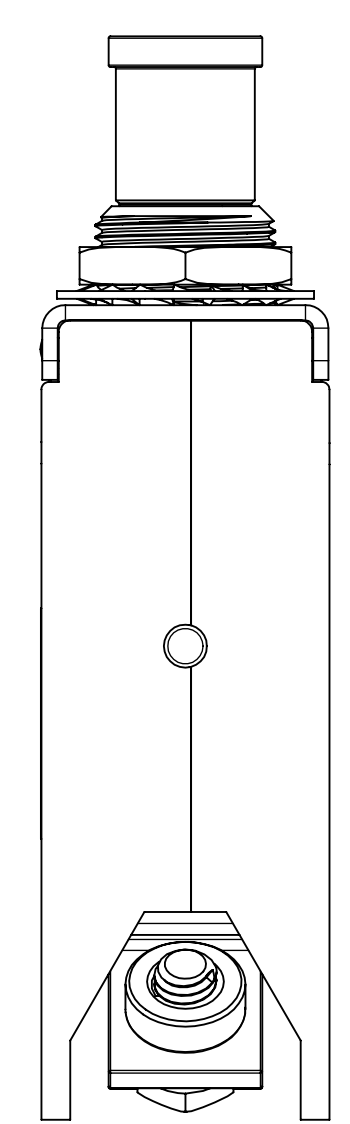
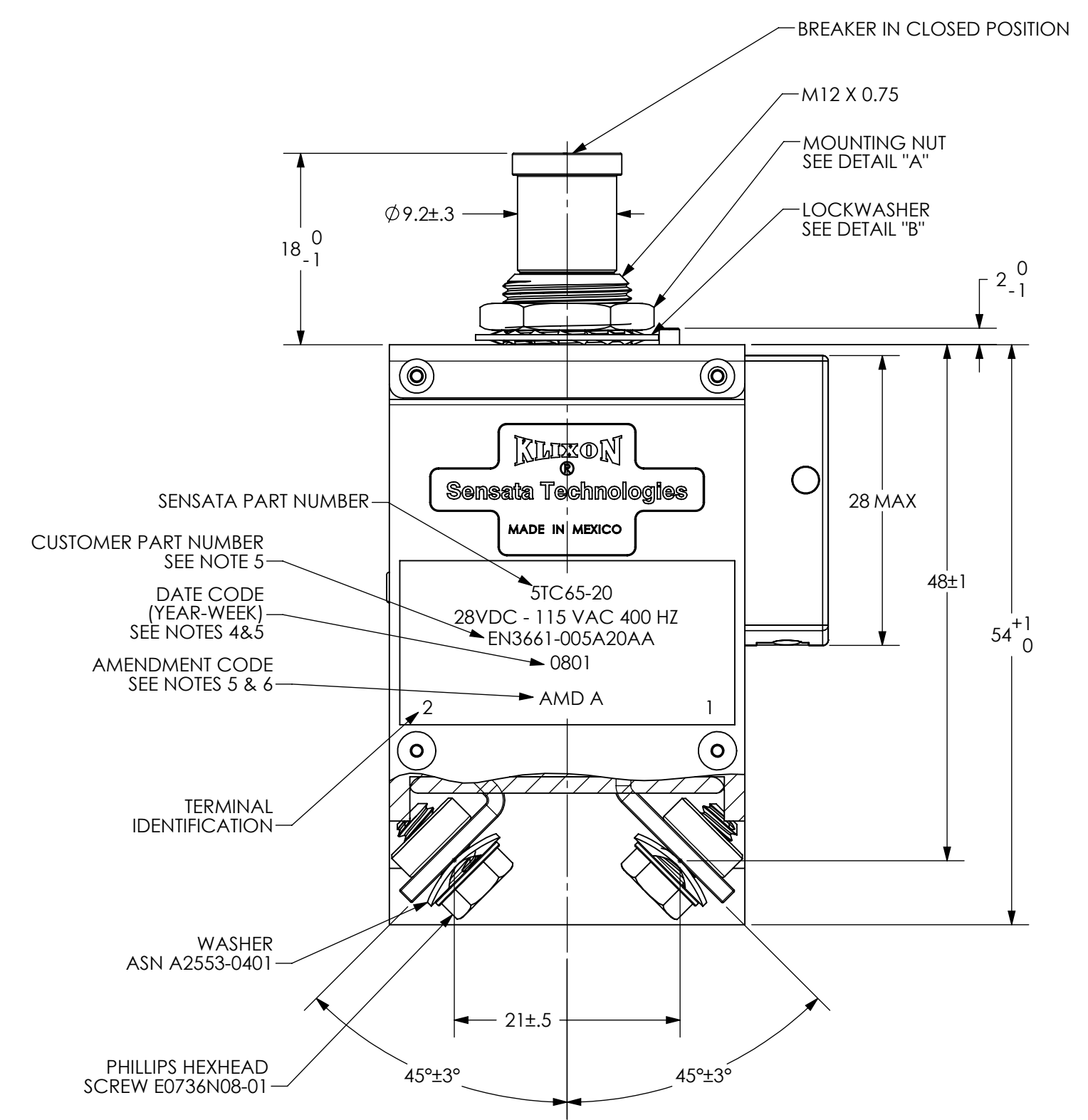

- NOTES:
- EPOXY SURFACES ARE NON-DIMENSIONED. ENVELOPE DIMENSIONS DO NOT APPLY TO THESE PROJECTED EPOXY SURFACES.
 - TERMINAL AND MOUNTING HARDWARE MAY BE PACKAGED RATHER THAN INSTALLED.
 - COUNTRY OF ORIGIN IS SHOWN FOR ILLUSTRATIONAL PURPOSES ONLY. COUNTRY OF ORIGIN TO BE IDENTIFIED AS REQUIRED.
 - DATE CODE PER 10588-285.
 - MARK IN APPROXIMATE POSITION SHOWN IN BLACK INK PER 12506-70.
 - INDICATES AMENDMENT TO THE ORIGINAL DESIGN.

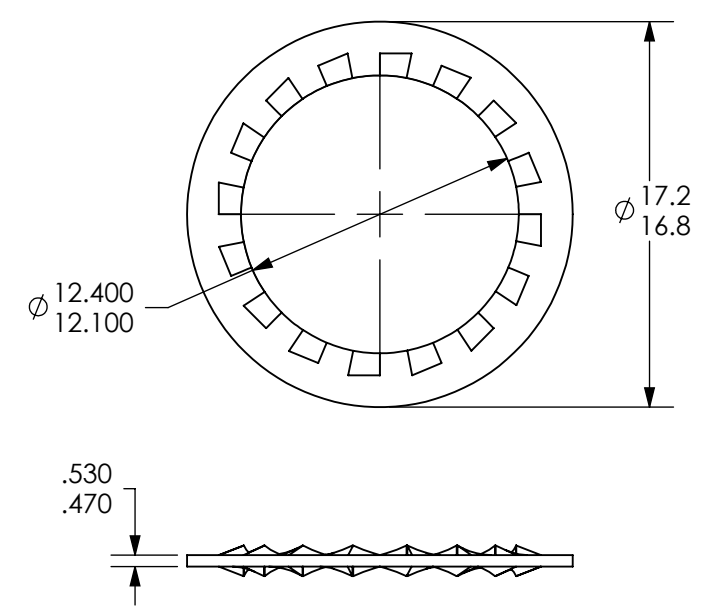
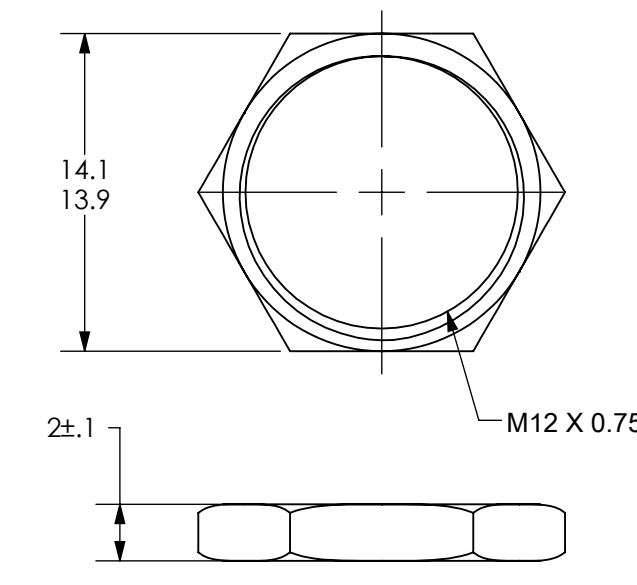
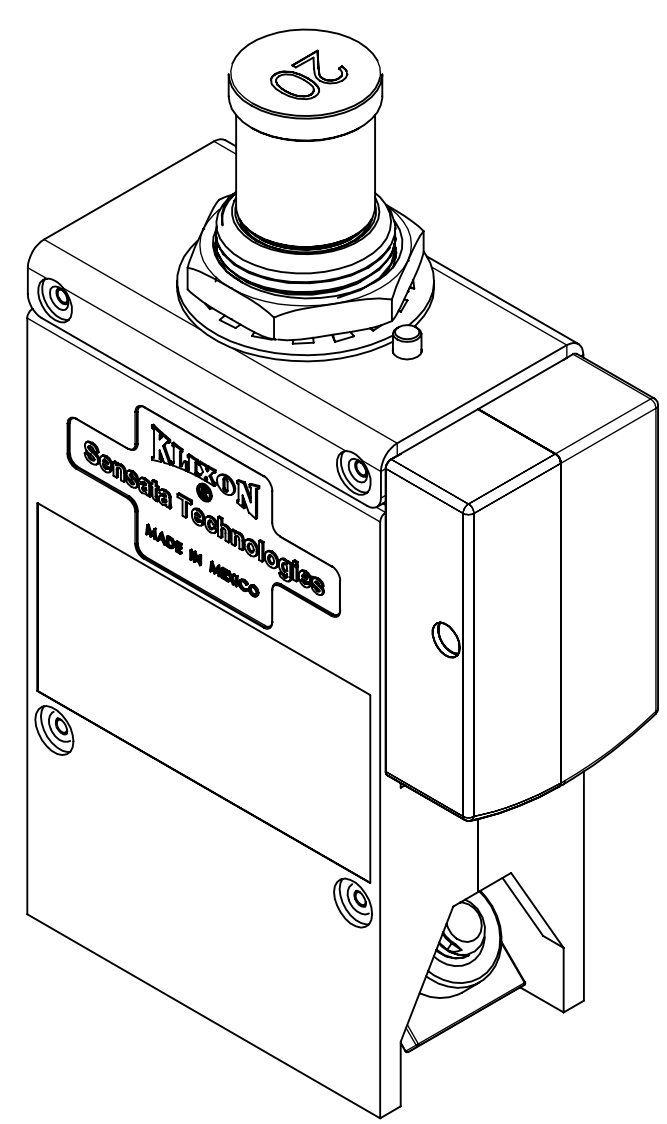

DETAIL "A"
MOUNTING NUT
BLACK FINISH
SCALE 3:1

DETAIL "B"
ROUNDELLE EVENTAIL JZE Ø 12
N° DERETEREVE 23 12 01 42
LOCKWASHER - BLACK FINISH
SCALE 3:1

FOR REFERENCE ONLY. CHECK LATEST REVISION BEFORE USE. PARTS MADE TO THIS PRINT MUST CONFORM TO E9898 REV. E.		529 PLEASANT STREET P.O. BOX 2964 ATTLEBORO, MA 02703	
DRAWN J.GONZALEZ DATE 03-SEP-1996	SENSATA TECHNOLOGIES PROPRIETARY AND CONFIDENTIAL. NEITHER THIS PRINT NOR THE INFORMATION CONTAINED HEREON IS TO BE USED AGAINST THE INTERESTS OF SENSATA TECHNOLOGIES OR AGAINST THE INTERESTS OF ANY OF ITS AFFILIATED COMPANIES OR WHOLLY OWNED SUBSIDIARIES.		TITLE 5TC65 CIRCUIT BREAKER PUSH PULL, TRIP FREE ENVELOPE DRAWING
ENGINEER N.WICKS DATE 03-SEP-1996	INTERPRET DIMENSIONING AND TOLERANCING PER ASME Y14.5-2009. UNLESS OTHERWISE SPECIFIED DIMENSIONS ARE IN MILLIMETERS.		SCALE A1
APPROVED K.MORSE DATE 03-SEP-1996	TOLERANCES DECIMALS ANGLES		DWG NO. 5TC65
APPROVED P.BERG DATE 03-SEP-1996	DO NOT SCALE DRAWING	THIRD ANGLE PROJECTION	REV. U
DEVICE: 5TC		PROJECT: 3695	SHEET 1 OF 1