

DR22 SERIES

DIN RAIL MOUNT SOLID STATE RELAYS

Sensata | Crydom DR22 Series Solid State Relays were developed to offer the advantages of semiconductor switching technology in a standard 22.5 mm industrial package. Quick and easy installation is coupled with low drive power requirements and efficient, reliable power SCR, TRIAC or MOSFET output. This compact new design offers up to 35 A_{RMS} in ambient temperatures of 40°C. Be sure to visit the product series datasheet available at the Sensata website to complement this information. If you have questions or need additional information please contact Sensata Tech Support.

MOUNTING INSTRUCTIONS

Please read all installation instructions before using your DR22 Series Solid State Relay (SSR).

- Install the relay on the DIN Rail (as shown in fig. 1) 50
- Maximum recommended terminal screw torque input terminal:
 - Contactor configuration ("V" & "W" suffixes): 5 in-lb (0.5 Nm)
 - Relay configuration ("U" suffix): 13-15 lb-in (1.5-1.7 Nm)
- Maximum recommended terminal screw torque load terminal:
 - Contactor configuration ("V" & "W" suffixes): 18-20 lb-in (2.0-2.2 Nm)
 - Relay configuration ("U" suffix): 13-15 lb-in (1.5-1.7 Nm)
- If multiple units are installed be sure to follow derating curves
- Recommended wire sizes as shown in TABLE 1

WARNING! Removing product from 35 mm rail incorrectly by not using the appropriate tool would damage the latching system.

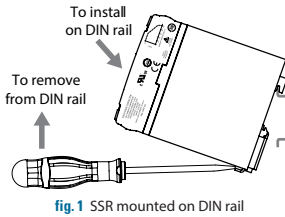

fig. 1 SSR mounted on DIN rail

TABLE 1. Recommended Wire Sizes			
Terminal Configuration	Wire Size (Solid / Stranded)	Wire Pull-Out Strength (lb)[N]	
Output Relay "U" suffix	2 x 18 AWG (1 mm ²) Stranded [minimum]	20 [88]	
	2 x 10 AWG (6 mm ²) Stranded [maximum]	60 [266]	
Input Relay "U" suffix	2 x 18 AWG (1 mm ²) Stranded	20 [88]	
	2 x 12 AWG (4 mm ²) Stranded	40 [177]	
Output Contactor "V" & "W" suffixes	2 x 20 AWG (0.75 mm ²) [minimum]	25 [111]	
	2 x 10 AWG (6 mm ²)	80 [355]	
	2 x 8 AWG (10 mm ²) [maximum]	90 [400]	
Input Contactor "V" & "W" suffixes	Screw	30 AWG (0.05 mm ²) [minimum]	4.5 [20]
		12 AWG (3.3 mm ²) [maximum]	30 [133]
	Spring	26 AWG (0.13 mm ²) [minimum]	5 [22]
		12 AWG (3.3 mm ²) [maximum]	5 [22]

TABLE 2. Compatible Terminals ^(A)				
Terminals	Fork Lug	Ring Lug	Copper Lug	Copper Lug
Part No.			TRM0	TRM6
Width [W] in (mm)	0.45 (11.4)	0.45 (11.4)		
Stud Size Dia [D] (in)	#8 (0.168)	#8 (0.168)		
Wire Size AWG			6-0	14-6

ORDERING OPTIONS

DR22	60	A	20	V	R	J
Series	DR22					
Operating Voltage	20: 1-200 VDC 24: 24-280 VAC (Low-profile version) 60: 48-600 VAC					
Control Voltage	A: 90-280 VAC/VDC (600 VAC Output only) D: 4-32 VDC 3-32 VDC (280 VAC Output)					
Rated Load Current	20: 20 Amps 30: 30 Amps 35: 35 Amps [High I ² t] (600 VAC Output only)					
Terminal Layout	U: Relay Configuration V: Contactor Configuration, Standard screw (600 VAC Output only) W: Contactor Configuration, Elevator screw (600 VAC Output only)					
Switching Type	Blank: Zero Voltage Turn-On (AC Output only) R: Instantaneous Turn-On (AC Output only)					
Input Connector	Blank: Screw Terminal J: Spring Terminal (V and W suffixes only)					

Required for valid part number
 For options only and not required for valid part number

WIRING DIAGRAM

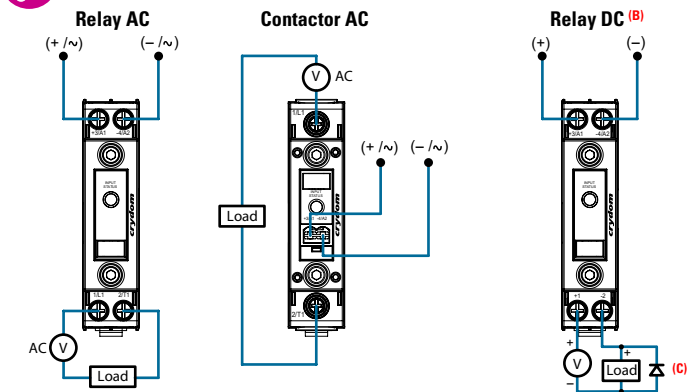

Important Considerations

- Be sure to use input and output voltages within operating ranges.
- LED indicates only input status. It does not represent output status.
- To achieve maximum ratings, there must be a minimum spacing of 0.89 in (22.5 mm) between the devices in free air (as shown in fig.2).
- Protective Earth (PE) screw type recommended is 10-32 UNC standard, not provided with SSR. Through the use of a DIN rail ground (protective conductor) terminal block, the DIN rail itself can be used as the grounding bus bar. In this case, the zinc plated steel material used for the DIN rail clip of DR22 models, permits a secure path to ground and avoid the need of a further PE connection (see fig.3).

0.89 in [22.5 mm] Minimum

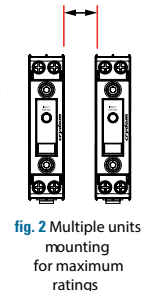

fig. 2 Multiple units mounting for maximum ratings

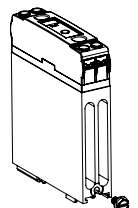

fig. 3 DR22 model with Protective Earth screw

ELEVATOR SCREW ("W" SUFFIX) CONSIDERATIONS

- The Elevator Screw option allows the screw and clamp to be raised out of the mating threads completely. This provides for the insertion and use of a ring or lug type wire terminal.
- A #2 Phillips head driver should be used with the Elevator Screws. If a powered driver is used, avoid speeds above 500 RPM.
- Cutting threads in the cover plastic as the screw elevates is key to the elevating feature. It has a finite life and therefore not recommended to be used more than 50 times during the product lifetime.
- Do not continue rotating the screw (in the elevating direction) once it freely rotates at the top of the plastic surface. The Elevator screw is capable of clearing 0.125 inches between the terminal and the bottom of the screw.
- Insertion of a terminal or lug thicker than 0.125 in is not recommended.
- When inserting the terminal ensure that the terminal hole is in line with the screw.
- During tightening, be certain that the terminal is seated flat within the cavity, and that the clamping washer is secure against the upper surface of the terminal.
- If fork terminations, spade lugs, or stranded wire are used, to prevent improper contact do not raise the elevator screw out of the mating threads.

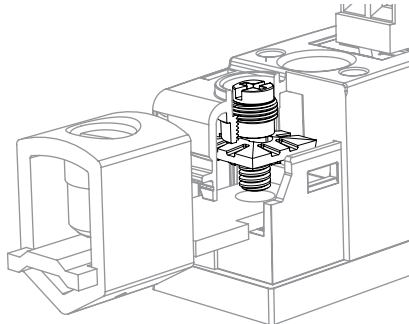

fig. 4 Elevator screw

PIN TERMINAL CONSIDERATIONS

- For 35 Amp Relay configuration (suffix "U") models use Pin Terminals (L 0.410 in x Ø 0.102 in) to install 8 AWG wire.
- To install, make sure screw is completely lifted to maximum position, and insert Pin terminal (as shown in fig. 5)
- Once installed, tighten terminal screws. Maximum recommended screw torque is 14 lb-in (1.58 Nm). Be sure to apply sufficient downward pressure while tightening the terminal screws to prevent the screw assembly from lifting.

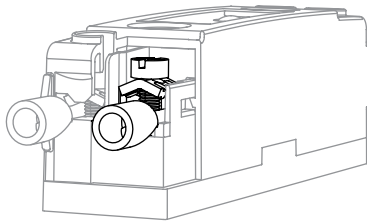

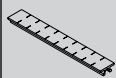

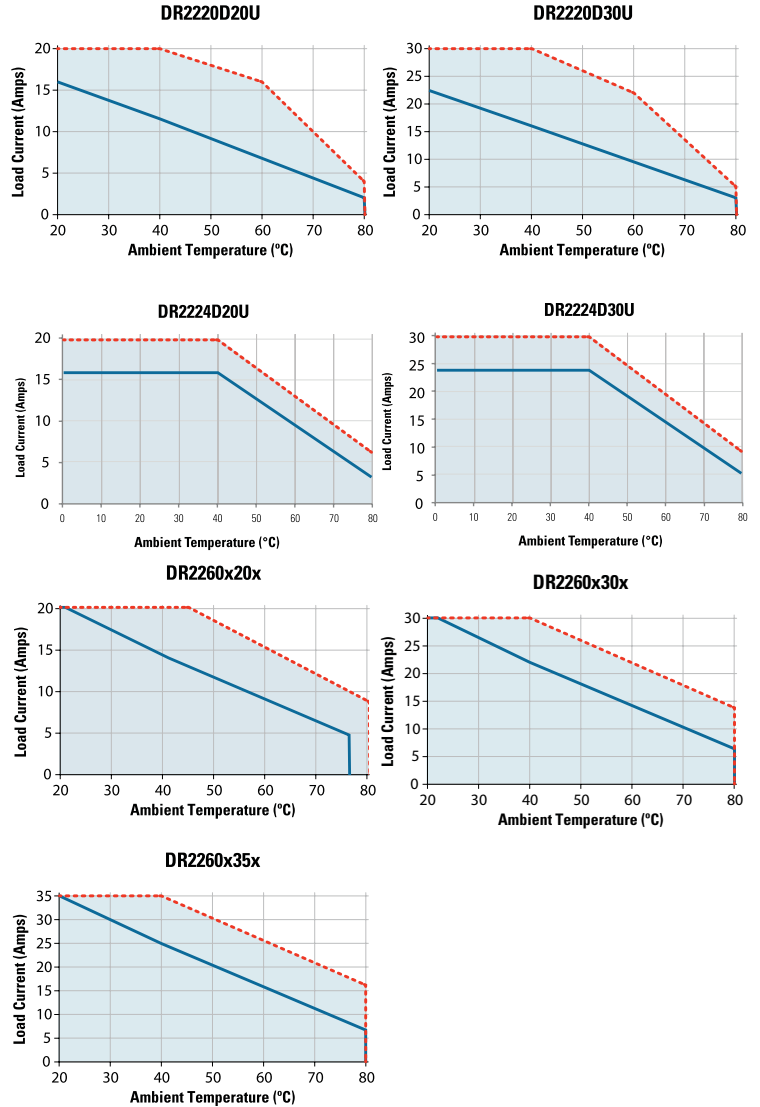

fig. 5 Pin Terminal

ACCESSORIES

TABLE 3. Recommended Accessories		
		
Connectors	ID Marker	Lug Terminal
CP201 CP202	CNLB CNLN CNL2	TRM0 TRM6

DERATING CURVES (D)



GENERAL NOTES

- Ring terminals and lug terminals are compatible only with relays with Elevator screw type terminals.
- Load can be wired to either terminal 1 or terminal 2. Proper polarity must be observed for the DC control power supply, with terminal 3 being positive with respect to terminal 4.
- DC inductive loads must be diode suppressed.
- AC input models operating range is -20 to 60 °C

Sensata Technologies, Inc. ("Sensata") data sheets are solely intended to assist designers ("Buyers") who are developing systems that incorporate Sensata products (also referred to herein as "components"). Buyer understands and agrees that Buyer remains responsible for using its independent analysis, valuation, and judgment in designing Buyer's systems and products. Sensata data sheets have been created using standard laboratory conditions and engineering practices. Sensata has not conducted any testing other than that specifically described in the published documentation for a particular data sheet. Sensata may make corrections, enhancements, improvements, and other changes to its data sheets or components without notice.

Buyers are authorized to use Sensata data sheets with the Sensata component(s) identified in each particular data sheet. HOWEVER, NO OTHER LICENSE, EXPRESS OR IMPLIED, BY ESTOPPEL OTHERWISE TO ANY OTHER SENSATA INTELLECTUAL PROPERTY RIGHT, AND NO LICENSE TO ANY THIRD PARTY TECHNOLOGY OR INTELLECTUAL PROPERTY RIGHT, IS GRANTED HEREIN. SENSATA DATA SHEETS ARE PROVIDED "AS IS". SENSATA MAKES NO WARRANTIES OR REPRESENTATIONS WITH REGARD TO THE DATA SHEETS OR USE OF THE DATA SHEETS, EXPRESS, IMPLIED, OR STATUTORY, INCLUDING ACCURACY OR COMPLETENESS. SENSATA DISCLAIMS ANY WARRANTY OF TITLE AND ANY IMPLIED WARRANTIES OF MERCHANTABILITY, FITNESS FOR A PARTICULAR PURPOSE, QUIET ENJOYMENT, QUIET POSSESSION, AND NON-INFRINGEMENT OF ANY THIRD PARTY INTELLECTUAL PROPERTY RIGHTS WITH REGARD TO SENSATA DATA SHEETS OR USE THEREOF.

All products are sold subject to Sensata's terms and conditions of sale supplied at www.sensata.com SENSATA ASSUMES NO LIABILITY FOR APPLICATIONS ASSISTANCE OR THE DESIGN OF BUYERS' PRODUCTS. BUYER ACKNOWLEDGES AND AGREES THAT IT IS SOLELY RESPONSIBLE FOR COMPLIANCE WITH ALL LEGAL, REGULATORY, AND SAFETY-RELATED REQUIREMENTS CONCERNING ITS PRODUCTS, AND ANY USE OF SENSATA COMPONENTS IN ITS APPLICATIONS, NOTWITHSTANDING ANY APPLICATIONS-RELATED INFORMATION OR SUPPORT THAT MAY BE PROVIDED BY SENSATA.

Mailing Address: Sensata Technologies, Inc., 529 Pleasant Street, Attleboro, MA 02703, USA

CONTACT US

Americas
+1 (877) 502 5500
sales.crydom@sensata.com

Europe, Middle East & Africa
+44 (1202) 416170
ssr-info.eu@sensata.com

Asia Pacific
sales.isasia@list.sensata.com
China +86 (21) 2306 1500
Japan +81 (45) 277 7117
Korea +82 (31) 601 2004
India +91 (80) 67920890
Rest of Asia +886 (2) 27602006 ext 2808