

## FEATURES

- > Tungsten contacts improve power performance\*\*
- > Meets or exceeds standards set in MIL-R-83725
- > Mounting options in any axis

## PRODUCT SPECIFICATIONS

Contact & Relay Ratings	Units	GH4
Contact Form		C
Contact Arrangement		SPDT
Contact Material (moveable/stationary)		molybdenum /tungsten
Dielectric		Vacuum
Voltage, Test Max., Contacts & to Base (15 µA Leakage Max.) dc or 60Hz	kV Peak	10
Voltage, Operating Max., Contacts & to Base (15 µA Leakage Max.) dc or 60 Hz	kV Peak	8
Current, Load Switching		Contact factory**
Current, Continuous Carry Max dc or 60 Hz	Amps	15
Coil Hi-Pot (V RMS, 60 Hz)	V	500
Resistance, Contact Max @ 1A, 28 Vdc	ohms	0.02
Operate Time	ms	6
Release Time	ms	6
Life, Mechanical	cycles	2 million
Weight, Nominal	g (oz)	39 (1.4)
Vibration, Operating, Sine (55-500 Hz Peak)	G's	10
Shock, Operating, 1/2 Sine 11ms (Peak)	G's	50
Temperature Ambient Operating	°C	-55 to +125

## COIL RATINGS

Nominal, Volts dc	12	26.5	115
Pick-up, Volts dc, Max.	8	16	80
Drop-Out, Volts dc	.5 - 5	1 - 10	5 - 50
Coil Resistance (Ohms ±10%)	80	335	6000

## PART NUMBER SYSTEM

GH4	
High Voltage/Power Terminal Connections	
Coil Voltage*	Blank = 26.5 Vdc -12Vdc = 12Vdc -115Vdc = 115Vdc

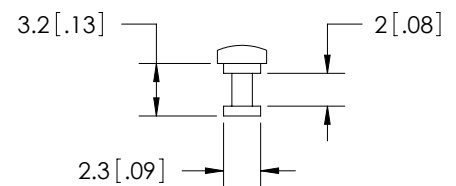
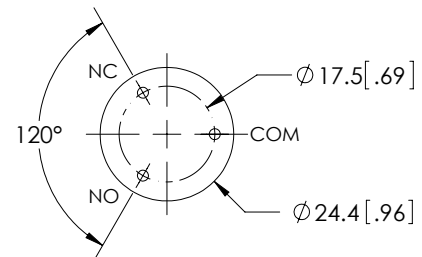
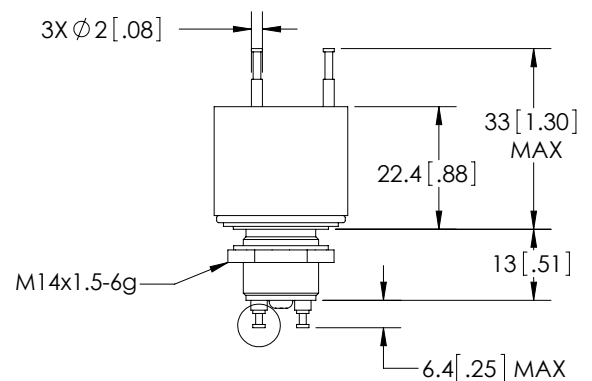

COIL DETAIL (3 : 1)

\* Order the relay with the coil voltage in the part number as shown above. The coil voltage will appear on the coil plate near the coil terminals rather than in the P/N on the relay.

\*\* Consult factory for load switching applications.

---

Datasheets provided by Sensata Technologies, Inc., its subsidiaries and/or affiliates (“Sensata”) are solely intended to assist third parties (“Buyers”) who are developing systems that incorporate Sensata products (also referred to herein as “components”). Buyer understands and agrees that Buyer remains responsible for using its independent analysis, valuation, and judgment in designing Buyer’s systems and products. Sensata datasheets have been created using standard laboratory conditions and engineering practices. Sensata has not conducted any testing other than that specifically described in the published documentation for a particular datasheet. Sensata may make corrections, enhancements, improvements, and other changes to its datasheets or components without notice.

Buyers are authorized to use Sensata datasheets with the Sensata component(s) identified in each particular datasheet. HOWEVER, NO OTHER LICENSE, EXPRESS OR IMPLIED, BY ESTOPPEL OR OTHERWISE TO ANY OTHER SENSATA INTELLECTUAL PROPERTY RIGHT, AND NO LICENSE TO ANY THIRD PARTY TECHNOLOGY OR INTELLECTUAL PROPERTY RIGHT, IS GRANTED HEREIN. SENSATA DATASHEETS ARE PROVIDED “AS IS”. SENSATA MAKES NO WARRANTIES OR REPRESENTATIONS WITH REGARD TO THE DATASHEETS OR USE OF THE DATASHEETS, EXPRESS, IMPLIED, OR STATUTORY, INCLUDING ACCURACY OR COMPLETENESS. SENSATA DISCLAIMS ANY WARRANTY OF TITLE AND ANY IMPLIED WARRANTIES OF MERCHANTABILITY, FITNESS FOR A PARTICULAR PURPOSE, QUIET ENJOYMENT, QUIET POSSESSION, AND NON-INFRINGEMENT OF ANY THIRD PARTY INTELLECTUAL PROPERTY RIGHTS WITH REGARD TO SENSATA DATASHEETS OR USE THEREOF.

All products are sold subject to Sensata’s terms and conditions of sale supplied at [www.sensata.com](http://www.sensata.com). SENSATA ASSUMES NO LIABILITY FOR APPLICATIONS ASSISTANCE OR THE DESIGN OF BUYERS’ PRODUCTS. BUYER ACKNOWLEDGES AND AGREES THAT IT IS SOLELY RESPONSIBLE FOR COMPLIANCE WITH ALL LEGAL, REGULATORY, AND SAFETY-RELATED REQUIREMENTS CONCERNING ITS PRODUCTS, AND ANY USE OF SENSATA COMPONENTS IN ITS APPLICATIONS, NOTWITHSTANDING ANY APPLICATIONS-RELATED INFORMATION OR SUPPORT THAT MAY BE PROVIDED BY SENSATA.

Mailing Address: Sensata Technologies, Inc., 529 Pleasant Street, Attleboro, MA 02703, USA

## CONTACT US

### Regional head offices:

#### United States of America

Sensata Technologies

Attleboro, MA

**Phone:** 508-236-3800

**E-mail:** [support@sensata.com](mailto:support@sensata.com)

#### Netherlands

Sensata Technologies Holland B.V.

Hengelo

**Phone:** +31 74 357 8000

**E-mail:** [support@sensata.com](mailto:support@sensata.com)

#### China

Sensata Technologies China Co., Ltd.

Shanghai

**Phone:** +8621 2306 1500

**E-mail:** [support@sensata.com](mailto:support@sensata.com)

Copyright © 2023 Sensata Technologies, Inc.