



# | High Voltage DC Contactor

GVB35 1000VDC BI-DIRECTIONAL CONTACTOR



## Features

- Gas filled design offers lower resistance than non-hermetic switches resulting in higher system efficiency and less heat generation. Meet IP67 level.
- Suppression gas allows high fault interrupt capability and prohibits oxidation--Strong capability of cooling arc, rapidly breaking current.
- High Efficiency Dual DC Coils – Very low 12, 24, or 48 VDC continuous coil power with no EMI emissions or cross-talk on your system control power. Ideal for battery powered systems or where low power is needed.
- Built-in coil suppression for all DC coils – Saves you engineering time and parts cost to add external coil suppression.
- Not position-sensitive – can be mounted in any position for ease of installation.
- Certification: CE/CCC, UL 60947-4-1

## Applications

- DC fast charging
- Energy storage systems
- Battery electric special mobility

## ● SPECIFICATIONS

### Electrical & Performance

Specifications		Data
Rated Voltage (V)		1000
Nominal Current (A)		500 <sup>9</sup>
Contact Arrangement	Main	SPST-NO
	Auxiliary <sup>1</sup>	SPST-NO
Mechanical Life (cycles)		300,000
Contact Resistance <sup>2</sup> (mΩ)	Max	0.2
	Typical	0.15
Short Circuit Withstand Current (ms)		20@4,000A
Insulation Resistance <sup>2</sup> (mΩ)		100@1000VDC
Dielectric at sea level (leakage<1mA)		4000VAC
Shock, ½ Sine, 11ms	Actuated (closed)	50G
	Non-Actuated (open)	25G
Vibration, Sinusoidal (10-2000Hz Peak)		25G
Environmental Seal		IP67 & IP69K
Salt Fog		MIL-STD-810
Max. Break Current @ 400V <sup>7</sup> (1 cycle)		±2000A
Max. Break Current @ 1000V <sup>7</sup> (1 cycle)		±500A
Electric Life (cycles) <sup>7</sup>	Break	6,000@1000VDC/80A
		20@1000VDC/250A
		100@850VDC/300A
		300,000@450VDC/20A
	Make	300,000@10VDC/50A
		1,000@450VDC/1350A

## COIL RATINGS at 25°C

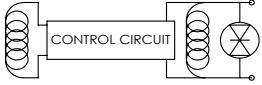
Coil P/N Designation	B <sup>6</sup>	C <sup>6</sup>	F <sup>6</sup>
Coil Voltage, Nominal (VDC)	12	24	48
Coil Type	Dual	Dual	Dual
Coil Voltage, Max (V)	16	32	64
Pick-Up Voltage, Max <sup>3,5</sup> (V)	8	16	32
Drop-Out Voltage <sup>3</sup> (V)	0.5	2	4
Pick-Up Current, Max <sup>4</sup> (A) (75 ms)	3.9	1.6	0.97
Coil Current <sup>5</sup> (A)	0.23	0.097	0.042
Coil Power <sup>3</sup> (W)	2.8	2.3	2.0
Operate Time, Max <sup>8</sup> (ms)	20		
Release Time, Max (ms)	12		
Internal Coil Suppression	TVS 		
Coil Back EMF (V)	55	55	125
Transients, Max (V) (13 ms)	±50	±50	±75
Reverse Polarity (V)	16	32	64

## CURRENT CARRY RATINGS

### CURRENT CARRY vs TIME

With 85 °C terminal temperature rise (Busbar 400MCM)

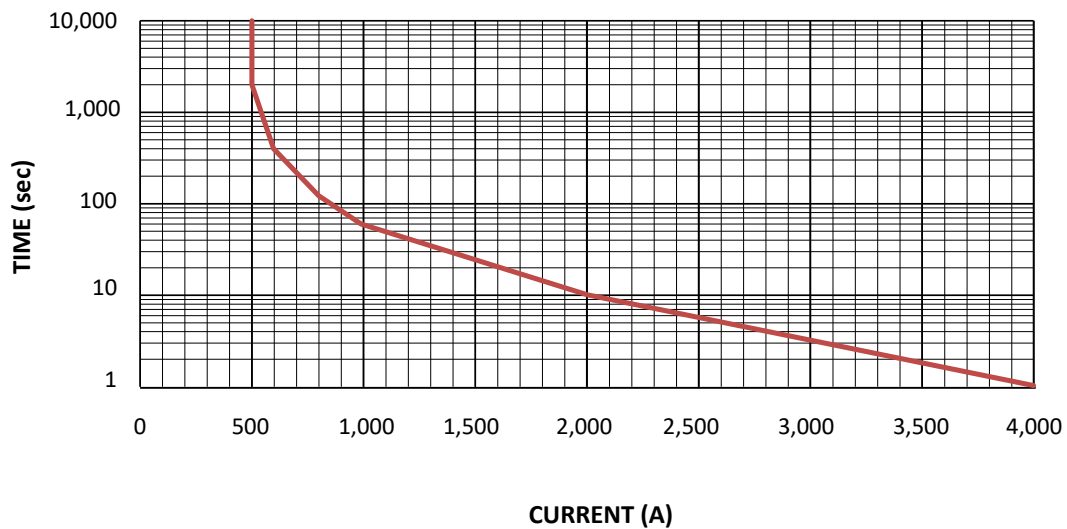

## DIMENSIONS

Dimensions are in mm (inches).

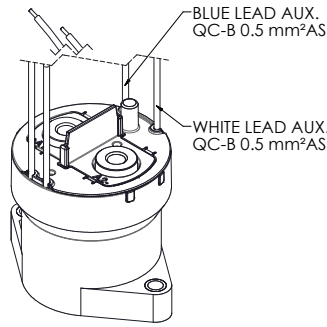
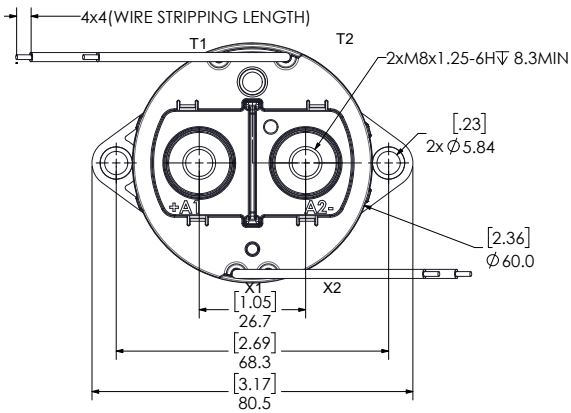

### Auxiliary Leads

B=SPST-NO

Blue Lead = T1

White Lead = T2

(Refer to Ordering Options section)

### Coil Leads

Red Lead = X1(+)

Black Lead = X2(-)

(Refer to Ordering Options section)

### Mounting

M5 or No. 10 Screws

Torque 1.7-4 Nm

### Power Connection

Silver Plated Copper M8x1.25 Terminals

Torque 10 Nm [90 in-lb] max

### Temperature and Weight

Operating ambient Temp Range = -55 to +85°C

Storage ambient Temp Range = -70 to +150°C

Weight, typical = 0.44 kg (0.97 lb)

### Packaging

24 units per shipping box

21 in x 18 in x 4 in shipping box

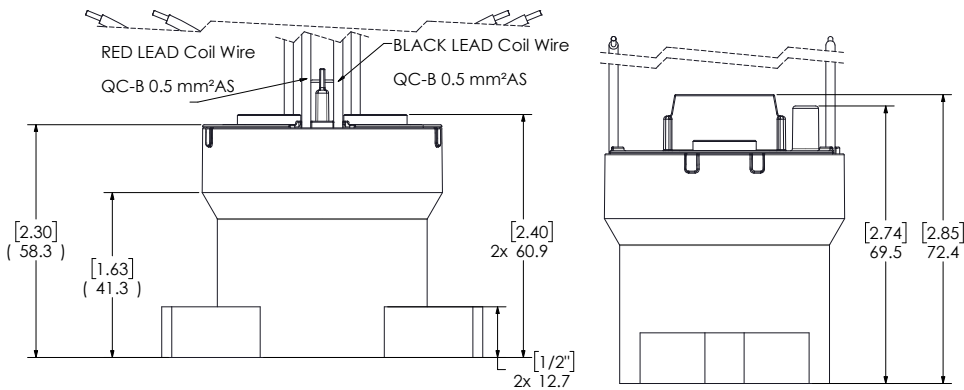

### Power Contacts

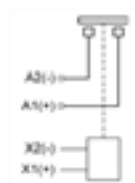

### Auxiliary Contacts

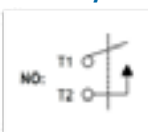

## SIDE MOUNT DIMENSIONS

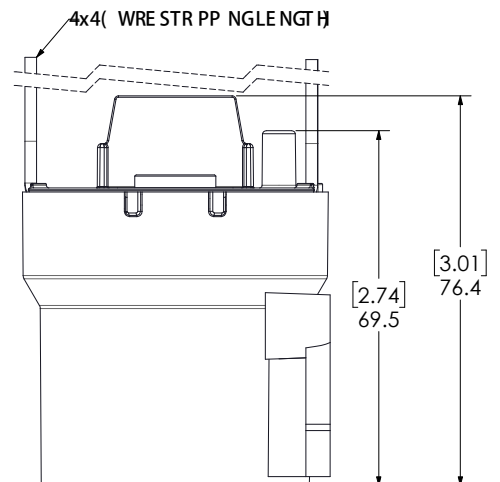
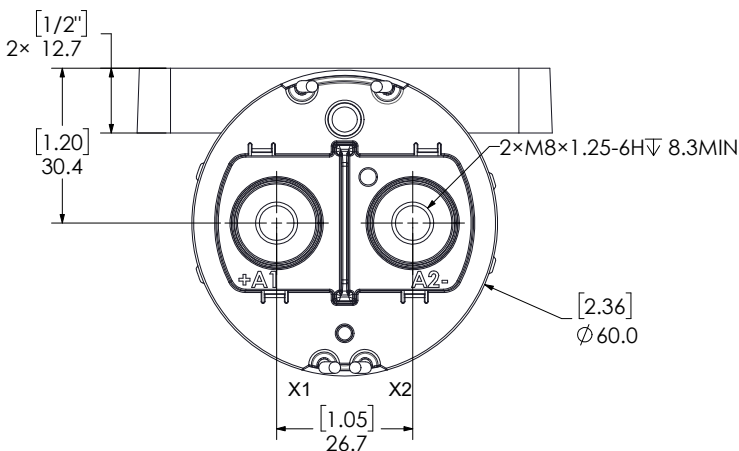

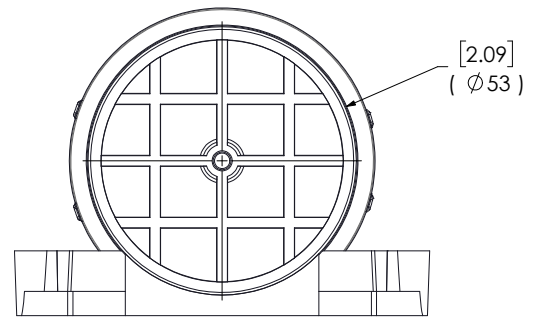
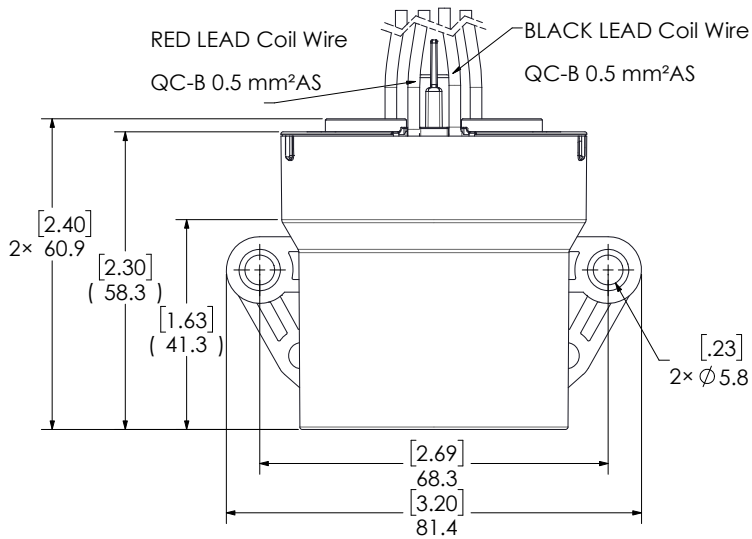

## ORDERING OPTIONS

Example: GVB351BAB

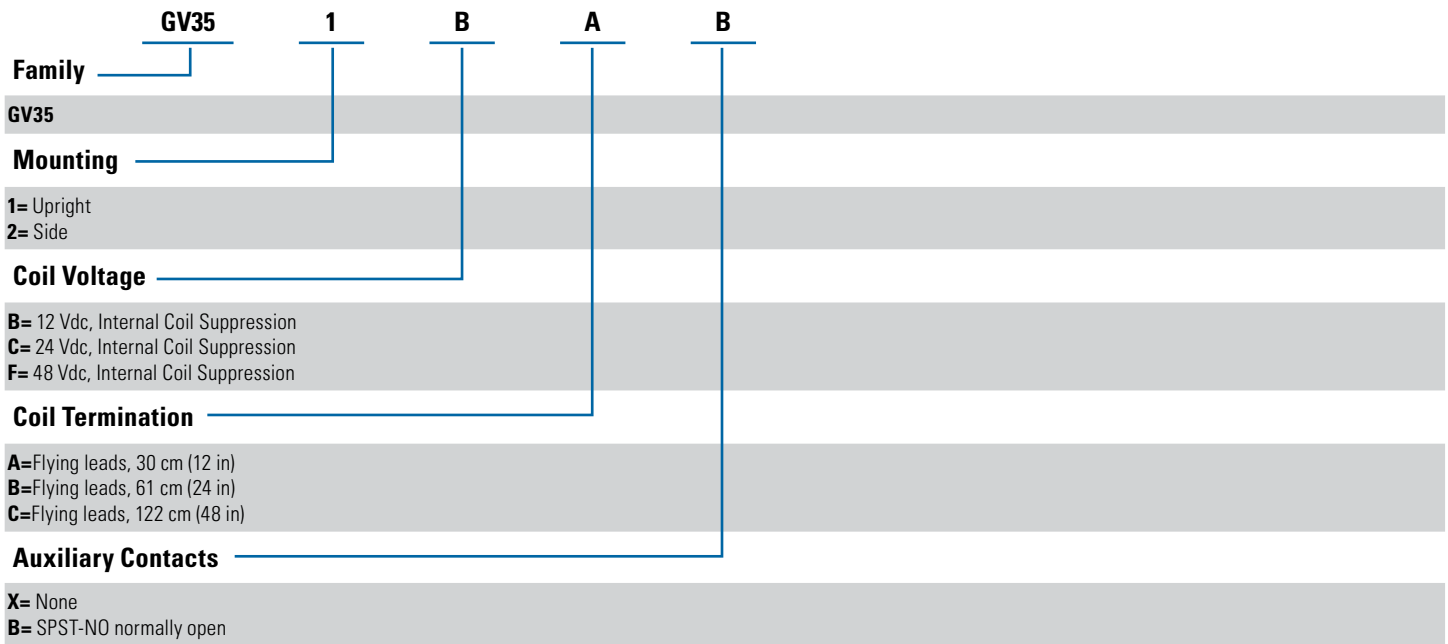

## GENERAL NOTES

1. Auxiliary contact rating is 2A, 24Vdc Resistive load, 100,000 cycles. Minimum current is 0.1mA, 5V. The auxiliary contact is mechanically linked to the main power contacts.
2. Insulation resistance is 50 MΩ after life.
3. Because the contactor is operated by a coil that changes resistance with temperature:  
Maximum coil voltage will be lower than indicated at temperatures above 25°C, and higher than indicated at temperatures below 25°C.  
And because Nominal Coil Voltage has been assumed for the Pick-up Current, Coil Current and Coil Power specifications, Current/Wattage will be lower than indicated at temperatures above 25°C and higher than indicated at temperatures below 25°C.  
Pick-up Voltage and Drop Out Voltage will be lower than indicated at temperatures below 25°C and higher than indicated at temperatures above 25°C.
4. Contactor has two coils. Both are used for pick-up, and then in approximately 75 milliseconds, one coil is electronically removed from the coil drive circuit. The remaining coil supplies low continuous hold power sufficient for the contactor to meet all its specified performance specifications. This provides the lowest coil power possible without the use of PWM electronics that have been known to cause EMI emissions and/or cross-talk on your system control power.
5. For Pick-up testing of contactors with dual coils, the voltage cannot be ramped up slowly, but must be applied instantly to at least the maximum Pick-up Voltage or Current. Otherwise, the contactor will not pick-up.
6. These DC coils have built-in coil suppression. The use of additional external coil suppression can slow the release time and invalidate the life cycle ratings, or can cause the contactor not to be able to interrupt the maximum current specified. If lower coil back EMF is required, please contact GIGAVAC for assistance.
7. All contact ratings and coil versions may not be UL recognized. Contact GIGAVAC for a copy of the applicable sections of the test report.
8. Operation time is measured at 25°C and includes maximum 7ms bounce.
9. Terminal temperature should be kept under 150°C under continuous carry conditions at an ambient of 85°C by applying the correct conductor size or active cooling. Failure to do so can result in overheating of the assembly and end of life of the product. Ambient temperature can impact terminal temperature rise and should be considered in the end application testing. UL recognized components are limited to 130°C external temperatures (Housing positions: top, middle and bottom). Please contact GIGAVAC for detailed information.

## TECHNICAL NOTES

- Contactors feature internal transient voltage suppressor for coil suppression. No external diodes should be added across the coil.
- Applications with capacitors will require a pre-charge circuit.
- Electrical life rating is based on resistive load with 27μH maximum inductance in circuit. Because your application may be different, we suggest you test the contactor in your circuit to verify life is as required.
- End of life is defined as when the dielectric, insulation resistance or contact resistance exceeds the specifications listed.
- Please avoid impact or drop of the contactor during application or transportation. In order to maintain the performance of the contactor, it is not recommended to continue to use the contactor after impact or fall.

## WARNINGS



### RISK OF MATERIAL DAMAGE AND HOT ENCLOSURE

- The product's side panels may be hot, allow the product to cool before touching
- Follow proper mounting instructions including torque values
- Do not allow liquids or foreign objects to enter this product

**Failure to follow these instructions can result in serious injury, or equipment damage.**



### HAZARD OF ELECTRIC SHOCK, EXPLOSION OR ARC FLASH

- Disconnect all power before installing or working with this equipment
- Verify all connections and replace all covers before turning on power

**Failure to follow these instructions will result in death or serious injury.**

Sensata Technologies, Inc. ("Sensata") datasheets are solely intended to assist designers ("Buyers") who are developing systems that incorporate Sensata products (also referred to herein as "components"). Buyer understands and agrees that Buyer remains responsible for using its independent analysis, valuation, and judgment in designing Buyer's systems and products. Sensata datasheets have been created using standard laboratory conditions and engineering practices. Sensata has not conducted any testing other than that specifically described in the published documentation for a particular datasheet. Sensata may make corrections, enhancements, improvements, and other changes to its datasheets or components without notice.

Buyers are authorized to use Sensata datasheets with the Sensata component(s) identified in each particular datasheet. HOWEVER, NO OTHER LICENSE, EXPRESS OR IMPLIED, BY ESTOPPEL OTHERWISE TO ANY OTHER SENSATA INTELLECTUAL PROPERTY RIGHT, AND NO LICENSE TO ANY THIRD PARTY TECHNOLOGY OR INTELLECTUAL PROPERTY RIGHT, IS GRANTED HEREIN. SENSATA DATASHEETS ARE PROVIDED "AS IS". SENSATA MAKES NO WARRANTIES OR REPRESENTATIONS WITH REGARD TO THE DATASHEETS OR USE OF THE DATASHEETS, EXPRESS, IMPLIED, OR STATUTORY, INCLUDING ACCURACY OR COMPLETENESS. SENSATA DISCLAIMS ANY WARRANTY OF TITLE AND ANY IMPLIED WARRANTIES OF MERCHANTABILITY, FITNESS FOR A PARTICULAR PURPOSE, QUIET ENJOYMENT, QUIET POSSESSION, AND NON-INFRINGEMENT OF ANY THIRD PARTY INTELLECTUAL PROPERTY RIGHTS WITH REGARD TO SENSATA DATASHEETS OR USE THEREOF.

All products are sold subject to Sensata's terms and conditions of sale supplied at [www.sensata.com](http://www.sensata.com) SENSATA ASSUMES NO LIABILITY FOR APPLICATIONS ASSISTANCE OR THE DESIGN OF BUYERS' PRODUCTS. BUYER ACKNOWLEDGES AND AGREES THAT IT IS SOLELY RESPONSIBLE FOR COMPLIANCE WITH ALL LEGAL, REGULATORY, AND SAFETY-RELATED REQUIREMENTS CONCERNING ITS PRODUCTS, AND ANY USE OF SENSATA COMPONENTS IN ITS APPLICATIONS, NOTWITHSTANDING ANY APPLICATIONS-RELATED INFORMATION OR SUPPORT THAT MAY BE PROVIDED BY SENSATA.

Mailing Address: Sensata Technologies, Inc., 529 Pleasant Street, Attleboro, MA 02703, USA

## CONTACT US

### Americas

Sensata GIGAVAC  
Contactor Center of Excellence  
6382 Rose Lane  
Carpinteria, CA 93013  
USA

Tel: +1 (805) 684 8401  
Email: [gigavac@sensata.com](mailto:gigavac@sensata.com)  
Sensata Global Headquarters  
Sensata Technologies  
529 Pleasant Street  
Attleboro, MA 02703  
USA

### Europe, Middle East & Africa

Sensata Technologies Holland B.V.  
Jan Tinbergenstraat 80  
7559 SP Hengelo  
The Netherlands  
Tel: +31743578000  
Email: [gigavac-info-eu@list.sensata.com](mailto:gigavac-info-eu@list.sensata.com)

### Asia Pacific

China  
Sensata Technologies China Co., Ltd.  
BM Intercontinental Business Center  
30th Floor  
100 Yu Tong Road  
Shanghai 200070  
People's Republic of China  
Tel: +8621 2306 1500  
Email: [contactorasia@list.sensata.com](mailto:contactorasia@list.sensata.com)  
Japan  
Sensata Technologies Japan Ltd.  
Shin Yokohama Square Bldg. 7F  
2-3- 12 Shin-yokohama  
Kohoku-ku, Yokohama-shi,  
Kanagawa 222-0033  
Tel: +81 45 277 7001  
Email: [contactorasia@list.sensata.com](mailto:contactorasia@list.sensata.com)