

Application Note AN-003

GX Coil Suppression

In order to limit the Back EMF to manageable levels, Gigavac's contactors have built-in suppression for all DC coils. The use of additional external coil suppression can slow the release time and invalidate the life cycle ratings, can cause contact welding at low current levels, and prevent the contactor from being able to interrupt the specified current.

The following oscillograph traces show the effect of a diode placed across the coil of a GX14C contactor. The current (blue trace) was measured using a 20mv/100A shunt. The source voltage (yellow trace) was 24 12V lead acid batteries connected in series. The drop in voltage seen when current is flowing is due to the internal battery resistance. The actual battery voltage sag is seen after the contacts open and is less than 10%. In all oscillographs the coil was turned on for 25ms.

Figure 1 shows an oscillograph of a GX14CA (with no external suppression) making and breaking 200A at 300Vdc ten times. Operate time is 9ms while release time is 9-11ms (the coil was turned on at the green triangle and turned off 25ms later).

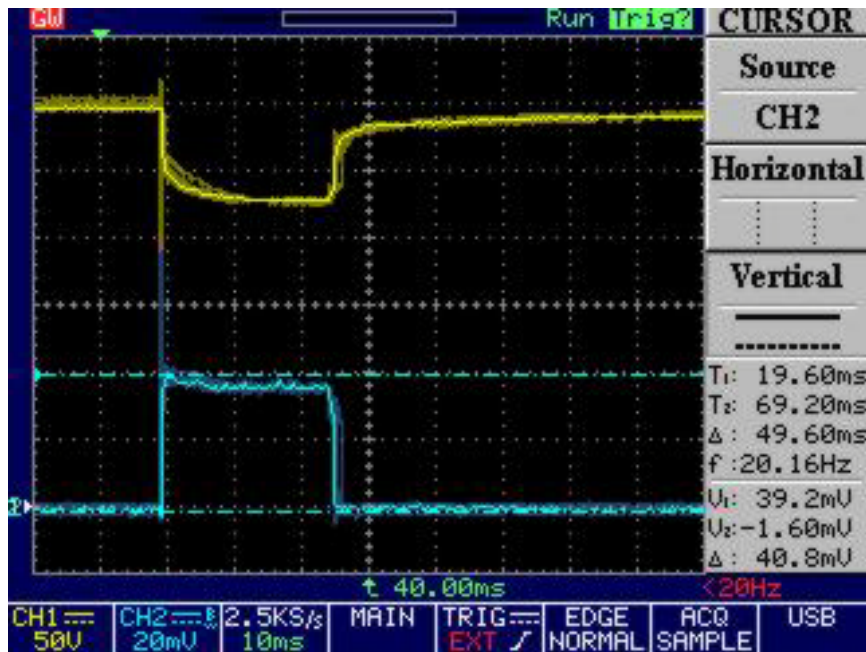

Figure 1. GX14CA, Make and Break 200A/300Vdc 10x

Figure 2 is again a GX14CA making and breaking 200A at 300Vdc ten times. This time a diode was installed across the coil. Operate time is now 5-9ms. The reduced operative time is caused by partial welding of the contacts due to reduced impact break. Since the contact gap has not fully opened the operate time is reduced. Release time has increased to 39-44ms due to coil current recirculating through the diode and causing the magnetic field to collapse very slowly.

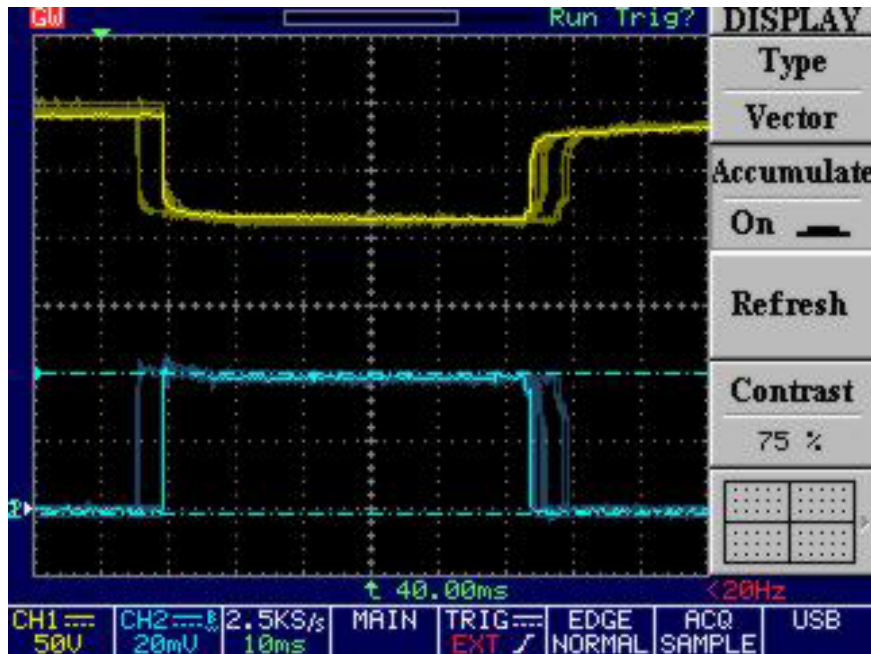

Figure 2. GX14CA w/ Diode, Make and Break 200A/300Vdc 10x

Figures 3 and 4 show a GX14 contactor breaking 200A/300Vdc 50 times. Figure 3 is without a diode and Figure 4 is with a diode. Notice without a diode the total arc time is very consistently controlled and is extinguished within 2ms. With a diode across the coil the arc time varies considerably from 1 to 4ms. This excessive arcing not only causes premature contact wear but can allow arcs to burn long enough to cause catastrophic failure.

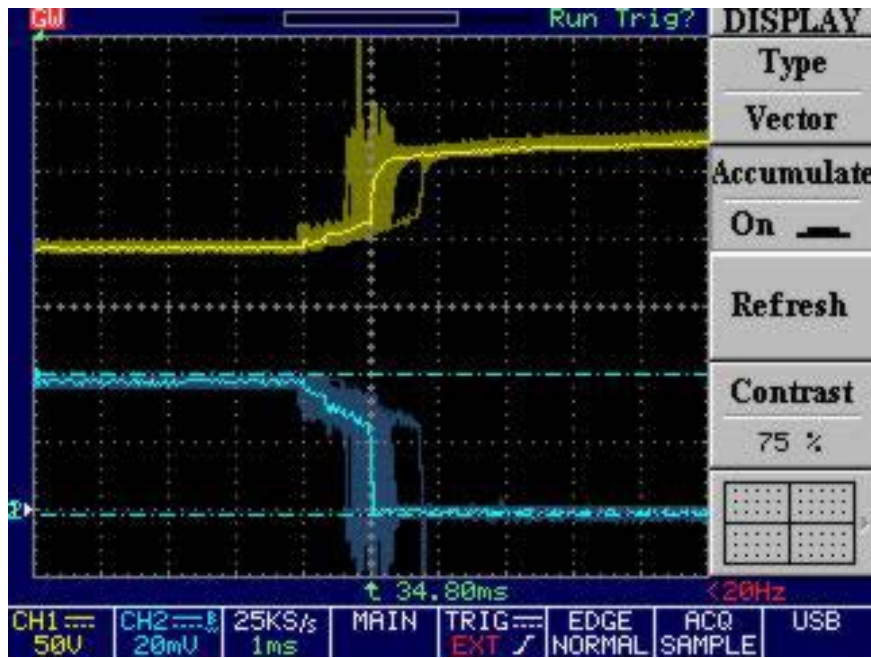

Figure 3.GX14CA, Break 200A/300Vdc 50x

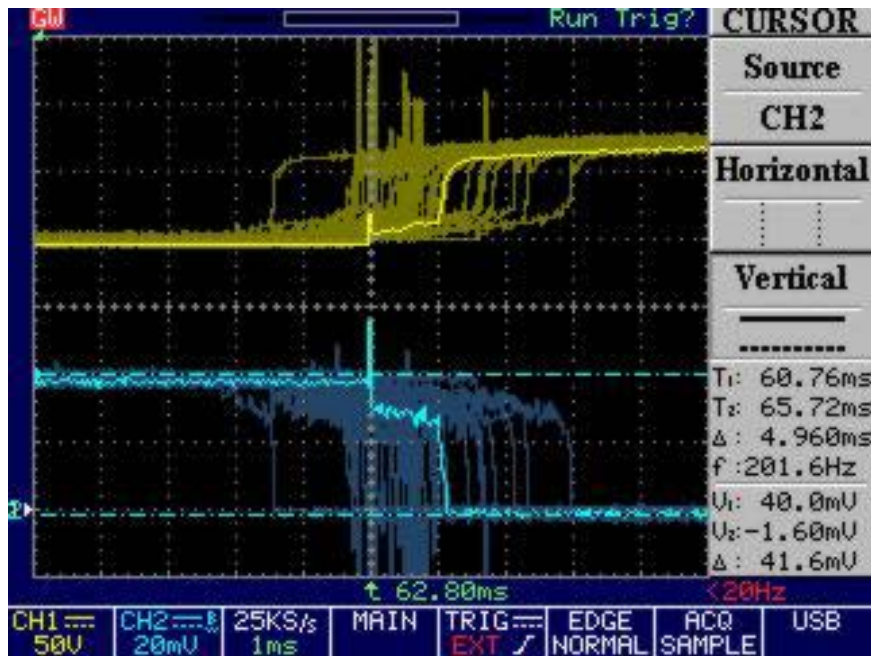

Figure 4. GX14CA with Diode, Break 200A/300Vdc 50x

Application

Figure 5 shows a typical driver circuit. Note that no coil suppression is used since the GX/MX contactors have integrated suppression. Figure 6 shows both the coil voltage and the voltage across the FET (V_d) when the contactor is turned off. Note that the FET needs to be rated for at least V_{in} plus the Specified Back EMF.

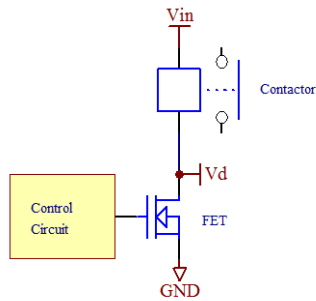

Figure 5. Typical Driver Circuit

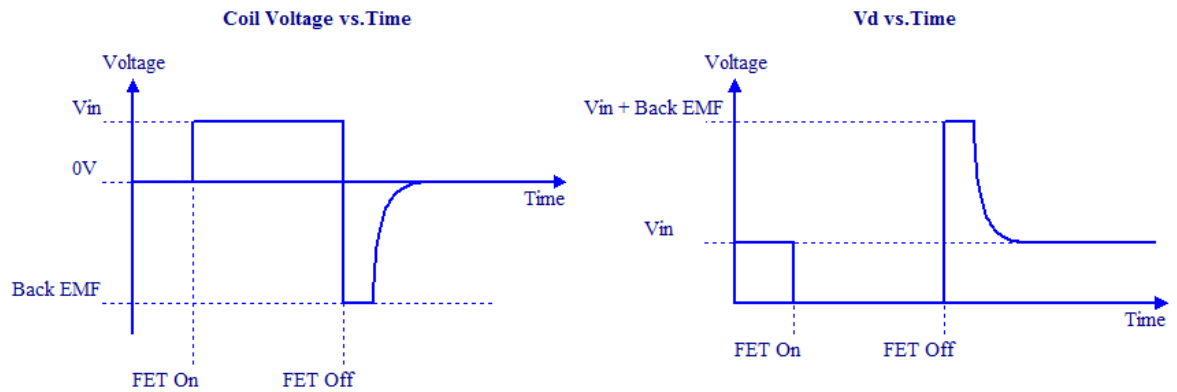

Figure 6. Coil Voltage and V_d vs. Time

If you have any questions you can always call us at 805-684-8401.