

Winding Constants *	Units	Tol	Symbol	Wdg	A
DC Resistance	Ohms	± 12.5%	R	17.1	
Voltage @ F <sub>p</sub>	Volts	Nominal	V <sub>p</sub>	27.2	
Current @ F <sub>p</sub>	Amps	Nominal	I <sub>p</sub>	1.59	
Force Sensitivity	LB/Amp	± 10%	K <sub>F</sub>	2.2	
	N/Amp	± 10%		9.79	
Back EMF Constant	V/(ft/sec)	± 10%	K <sub>B</sub>	2.98	
	V/(m/sec)	± 10%		9.79	
Inductance ****	milli-Henry	± 15%	L	2.8	

Linear Actuator Parameters *	Units	Symbol	Value
Peak Force **	LB	F <sub>p</sub>	3.5
	N		15.57
Continuos Stall Force ***	LB	F <sub>CS</sub>	1.14
	N		5.07
Actuator Constant	LB/√Watt	K <sub>A</sub>	0.53
	N/√Watt		2.36
Electrical Time Constant	micro-sec	τ <sub>E</sub>	164
Mechanical Time Constant	milli-sec	τ <sub>M</sub>	3.16
Theoretical Acceleration	ft/sec <sup>2</sup>	α <sub>T</sub>	2886.1
	m/sec <sup>2</sup>		879.7
Max Theoretical Frequency @ Full Stroke and Sinusoidal / Triangular Motion	Hz	f <sub>max</sub>	83.8/93.1
Power I <sup>2</sup> R @ F <sub>p</sub>	Watts	P <sub>p</sub>	43.3
Stroke:	± in		0.125
	± mm		3.18
Clearance on Each side of Coil	in		0.015
	mm		0.38
Thermal Resistance of Coil in still air	°C/Watt	θ <sub>TH</sub>	18.7
Maximum Allowable Coil Winding Temp	°C	Temp	155
Weight of Coil Assembly	LB	WT <sub>C</sub>	0.039
	g		17.7
Total Weight	LB	WT <sub>T</sub>	0.28
	g		127

\* AT MID-STROKE POSITION AND @ 25 °C AMBIENT TEMPERATURE.  
 \*\* 10 SECONDS @ 25 °C AMBIENT & 155 °C COIL TEMPERATURE.  
 \*\*\* @25 °C AMBIENT & 155 °C COIL TEMPERATURE.  
 \*\*\*\* MEASURED AT 1000 Hz.

POSITION SENSOR		
LEAD WIRE	IDENTIFICATION	DESCRIPTION
YELLOW	V <sub>CC</sub>	INPUT VOLATAGE ( 5 VOLTS)
GRAY	GND	GROUND
BROWN	V <sub>O</sub>	OUTPUT VOLTAGE
WHITE	V <sub>PP</sub>	VOLTAGE FOR PROGRAMMING ONLY, NOT TO BE USED BY CUSTOMER

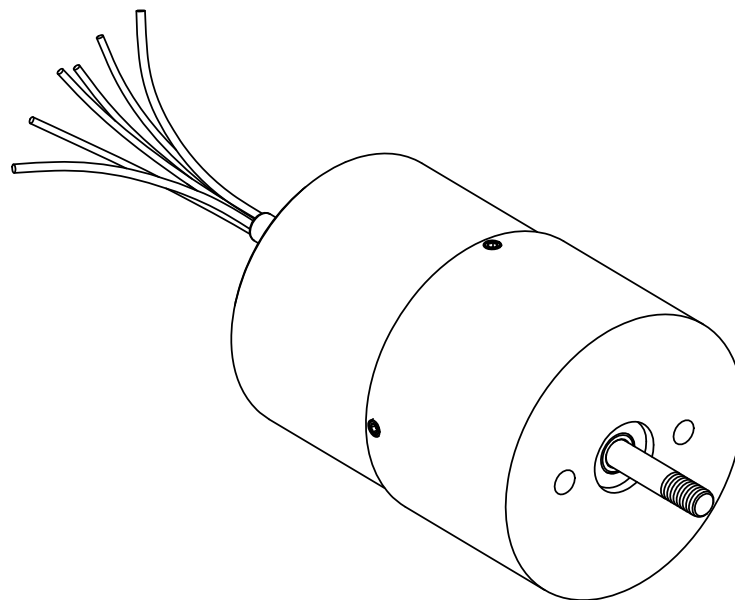

ZONE	REV.	REVISION DESCRIPTION	ECN NO.	DATE
	X2			

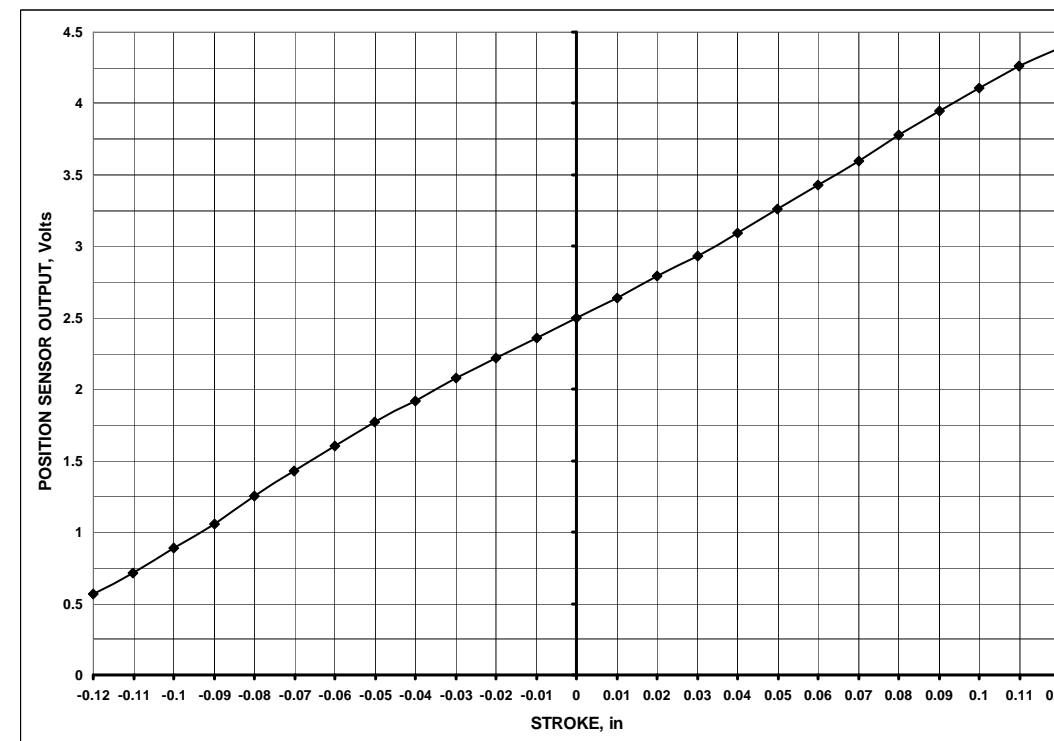
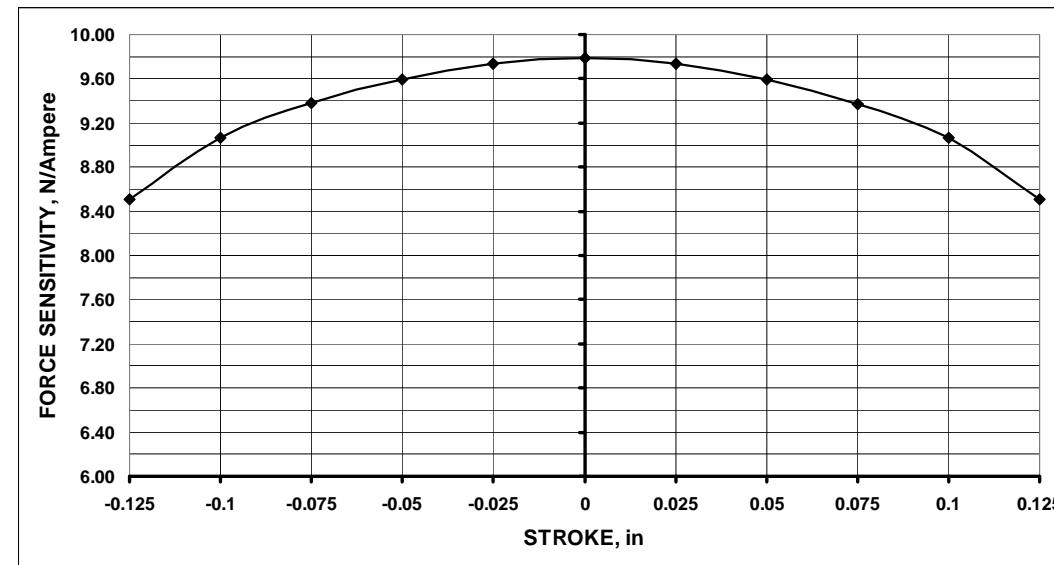

SOLIDWORKS

FOR REFERENCE ONLY, CHECK LATEST REVISION BEFORE USE.		 529 PLEASANT STREET P.O. BOX 2964 ATTLEBORO, MA 02703
DRAWN DATE ENGINEER DATE APPROVED M. GODKIN DATE 05/31/19 APPROVED	SENSATA TECHNOLOGIES PROPRIETARY AND CONFIDENTIAL. NEITHER THIS PRINT NOR THE INFORMATION CONTAINED HEREON IS TO BE USED AGAINST THE INTERESTS OF ANY OF ITS AFFILIATED COMPANIES OR WHOLLY OWNED SUBSIDIARIES. INTERPRET DIMENSIONING AND TOLERANCING PER ASME Y14.5-2009. UNLESS OTHERWISE SPECIFIED DIMENSIONS ARE IN INCHES. TOLERANCES DECIMALS      ANGLES X.X      ± 0.03      X.X° ± 0°30' X.XX      ± 0.01 X.XXX      ± 0.005	
DO NOT SCALE DRAWING THIRD ANGLE PROJECTION		TITLE <b>LINEAR ACTUATOR SYSTEM</b> SIZE DWG NO. REV. C LAS13-18-000A-P01-DASH X2 SCALE 2:1 SHEET 1 OF 2

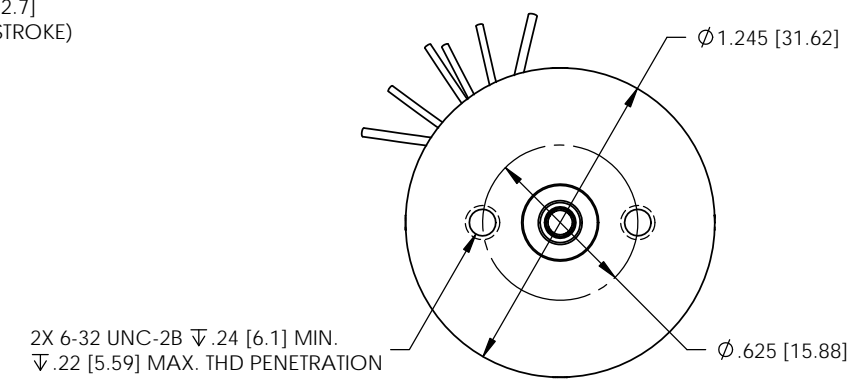
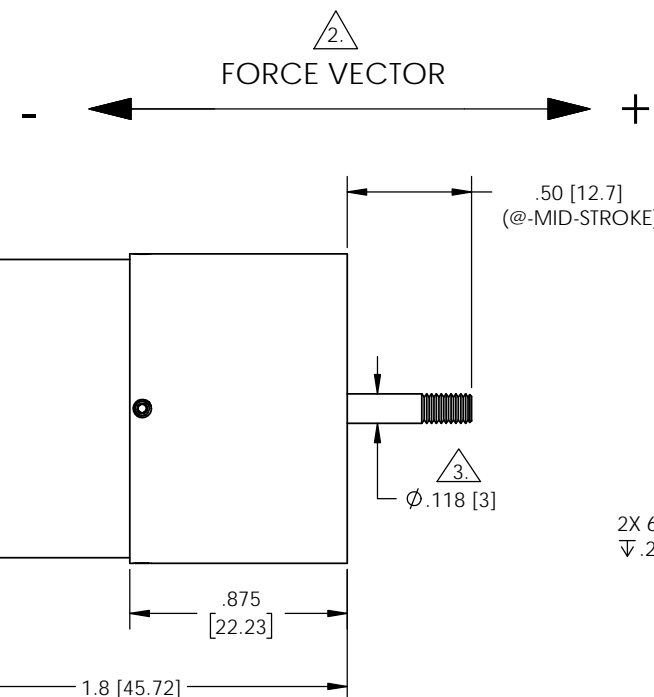
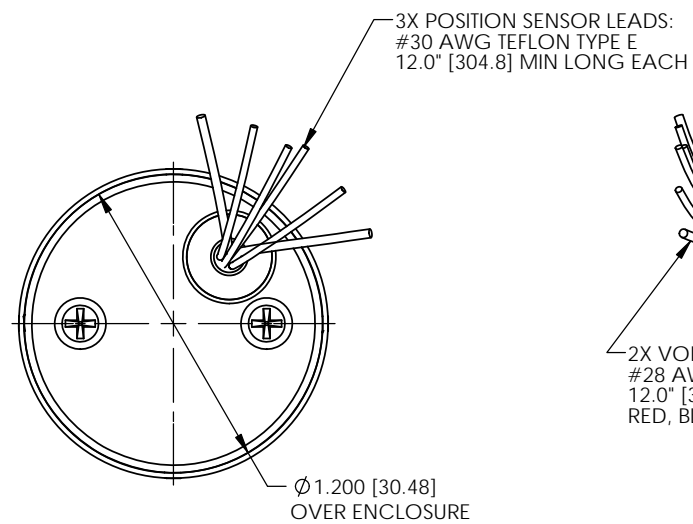

(DASH)#	SHAFT END CONFIGURATION
-3S	3mm Diameter
-3E	3mm Diameter, External Thread M3x0.5 X .2 [5.08mm] Long

NOTES: UNLESS OTHERWISE SPECIFIED

1. INCH DRAWING. DIMENSIONS IN BRACKETS [ ] ARE IN MILLIMETERS AND ARE FOR REFERENCE ONLY.

2. A POSITIVE (+) VOLTAGE APPLIED TO THE RED LEAD WILL PRODUCE A FORCE ON THE COIL ASSEMBLY (SHAFT) IN THE POSITIVE (+) DIRECTION.

3. -3E SHAFT CONFIGURATION SHOWN.

**Sensata Technologies**  
529 PLEASANT STREET  
P.O. BOX 2964  
ATTLEBORO, MA 02703

SIZE	DWG NO.	REV.
C	LAS13-18-000A-P01-DASH	X2
SCALE	2:1	SOLIDWORKS SHEET 2 OF 2

