

# MHM5

## DEVICE NET ABSOLUTE MULTI-TURN ENCODER



### Features

MHM510, standard encoder Ø58mm with DeviceNet interface:

- Robust and compact design
- Solid shaft version Ø 10 mm (06 mm available upon request)
- Precision ball bearings with sealing flange
- High temperatures performances -40°C ... +85°C
- Code disc made of unbreakable and durable plastic
- Mechanical memorisation of the number of turns by gears
- Resolution: 13 bits = 8192 steps/turn (max 16 bits)
- Number of Turns : 12 bits = 4096 turns (max 14 bits)
- Polarity inversion and short circuit protection
- Highly integrated circuit in SMD-technology

## SPECIFICATIONS

### Mechanical

<b>Material</b>	<b>Cover:</b> Aluminum
	<b>Body:</b> Aluminum
	<b>Shaft:</b> Stainless Steel
<b>Max. Shaft Loading</b>	<b>Axial:</b> 40 N
	<b>Radial:</b> 110 N
<b>Shaft Inertia</b>	≤ 30 g.cm <sup>2</sup>
<b>Torque</b>	≤ 3 N.cm
<b>RPM (Continuous Operation)</b>	6 000 tr/min
<b>Shock (EN 60068-2-27)</b>	≤ 100 g (half-sinus, 6 ms)
<b>Shock (EN 60028-2-29)</b>	≤ 10 g (half-sinus, 16ms)
<b>Vibrations (EN 60068-2-6)</b>	≤ 10 g (10Hz... 1 000Hz)
<b>Weight</b>	600 g
<b>Operating Temperature</b>	- 40 ... + 85°C
<b>Storage Temperature</b>	- 40 ... + 85°C
<b>Humidity</b>	98 % without Condensation
<b>Protection Class (EN 60529)</b>	IP65: cover

Lifetime in 10 <sup>8</sup> Revolutions with F <sub>a</sub> / F <sub>r</sub> (Axial / Radial)		
40 N / 60 N	40 N / 80 N	40 N / 110 N
25	10	4

## Electrical

<b>Interface</b>	Transceiver According ISO/DIS 11898
<b>Transmission Rate</b>	Max 500KBauds
<b>Device Addressing</b>	By Rotary Switches
<b>Power Supply</b>	10 – 30Vdc
<b>Current Consumption</b>	Max. 100mA (24Vdc)
<b>Power Consumption</b>	Max 2,5W
<b>Step Frequency LSB</b>	800 kHz
<b>Accuracy of Division</b>	+ ½ LSB
<b>EMC</b>	EN 61000-6-4 EN 61000-6-2
<b>Electrical Lifetime</b>	> 10 <sup>5</sup> h



## DIMENSIONS

All dimensions are in millimeters.

### MHM510-DNET (Connection Cap Included)

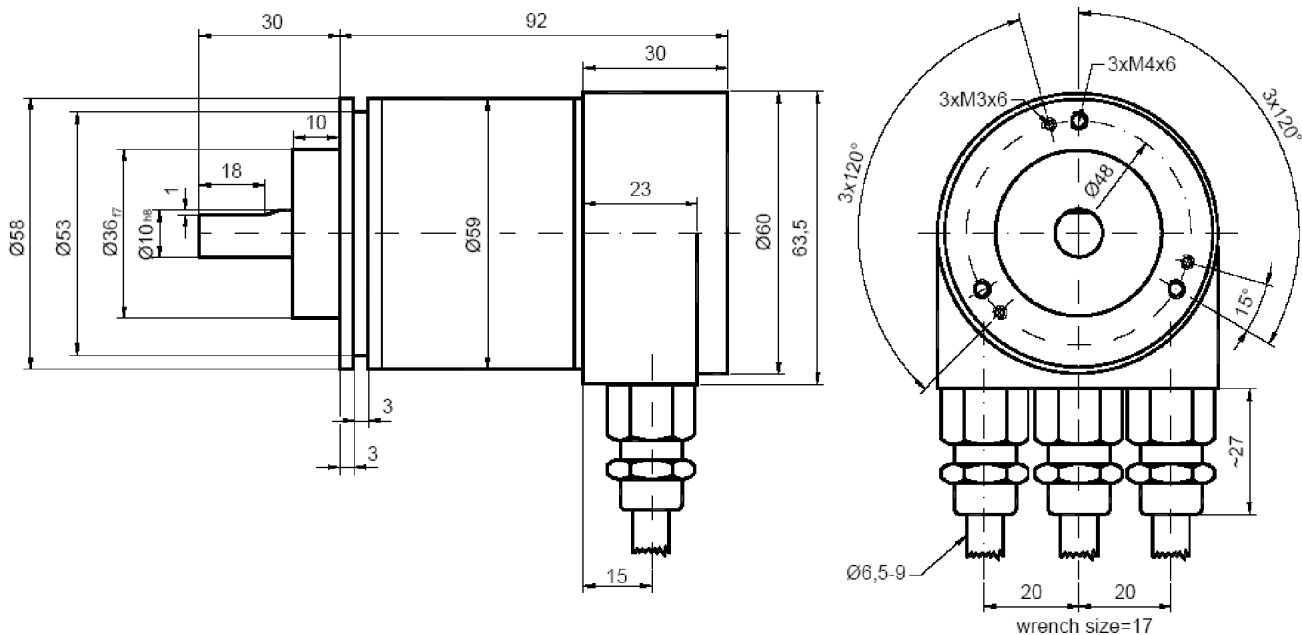

Status visualization by 2 LED's at the back of the connection cap

Sta - Green LED	Meaning
Off	No Power Supply
On	Encoder is ready, Boot Up message not sent (no further device on network, wrong baud rate) or encoder in prepared status
On	Boot Up message sent, device configuration is possible
On	Normal operation mode, Encoder in Operational Status

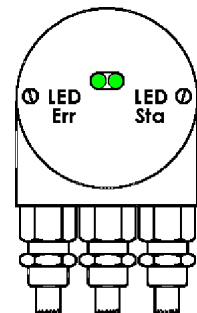

## Transmission Mode

<b>Polled Mode</b>	By a telegram the connected host calls for the current process value. The absolute rotary encoder reads the current position value, calculates eventually set-parameters and sends back the obtained process value by the same identifier
<b>Change of State</b>	The absolute rotary encoder transmits the actual process value. The process value is transmitted when the position changes. This is useful to reduce the bus activity
<b>CYCLIC Mode</b>	The absolute rotary encoder transmits the actual process value event controlled by an internal timer. This is also useful to reduce the bus activity

## Programmable Parameters

<b>Operating Parameters</b>	As operating parameters the code sequence (complement) can be programmed. This parameter determines the counting direction, in which the output code increases or decreases
<b>Resolution (pos./turn)</b>	The parameter resolution per revolution is used to program the desired number of steps per revolution. Value between 1 and 8 192 can be programmed
<b>Total Resolution "Max-RANGE"</b>	This parameter is used to program the desired number of measuring units over the total measuring range. This value may not exceed the total resolution of the absolute rotary encoder. If the encoder is used in a continuous measuring application, certain rules for the setting of this parameter must be followed. These rules are outlined in the manual
<b>Preset Value</b>	The preset value is the desired position value, which should be reached at a certain physical position of the axis. The position value is set to the desired process value by the parameter pre-set

## Installation

The rotary encoder is connected by three cables. The power supply is achieved with a two-wire connection cable through one PG 9. Each one of the twisted-pair and shielded bus lines are guided in and out through two PG 9 on the right side (as seen on clamps).

## Configuration

The setting of the node number is achieved by 2 turn-switches in the connection cap. Possible addresses lie between 0 and 63 whereby every address can only be used once. 2 LEDs on the backside of the connection cap show the operating status of the encoder.

There is a resistor provided in the connection cap, which must be used as a line termination on the last device.

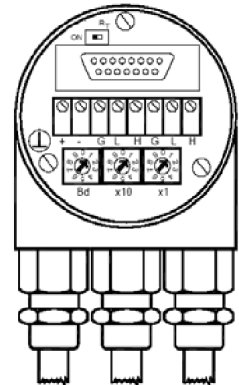



# ORDERING REFERENCE

Example : **MHM5 - D2 B1 B - 12 13 - C 10 0 - H3P**

Contact the factory for special versions, ex: special flanges, electronics, connections...

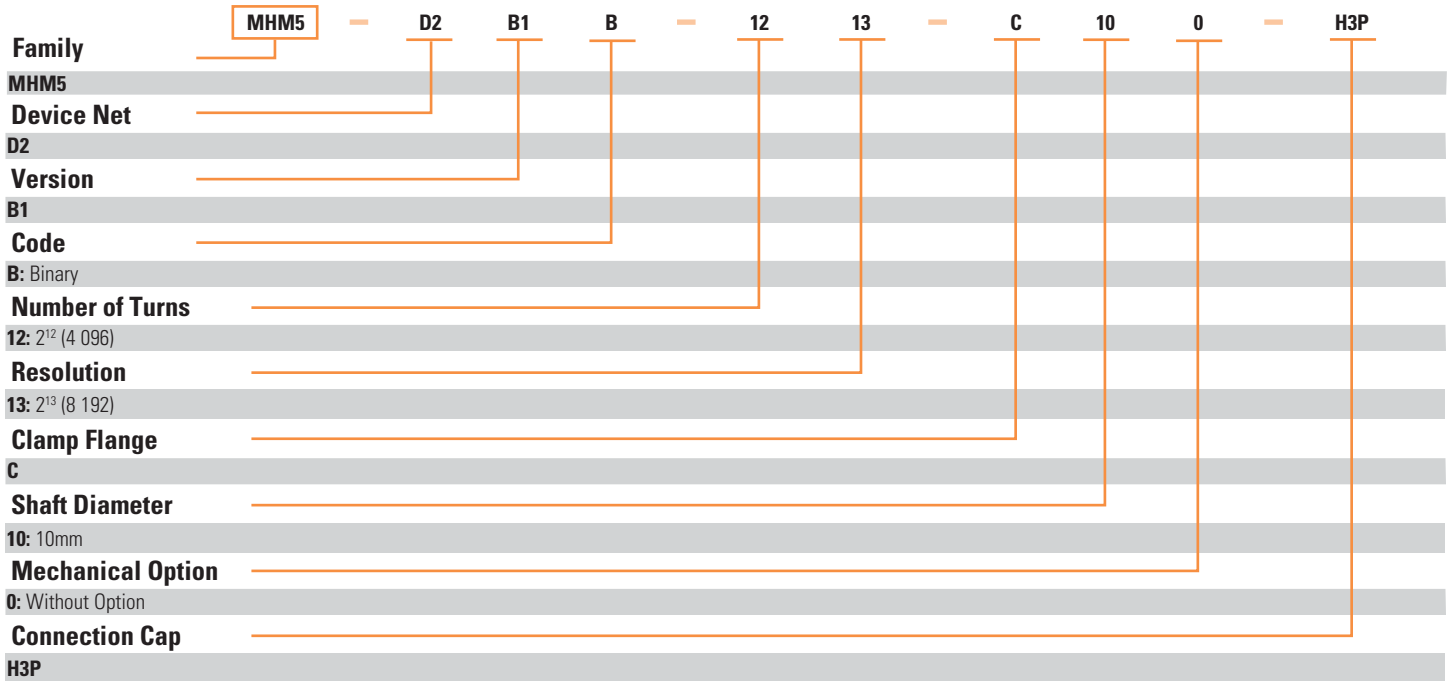

# AGENCY APPROVALS & CERTIFICATIONS



Sensata Technologies, Inc. ("Sensata") data sheets are solely intended to assist designers ("Buyers") who are developing systems that incorporate Sensata products (also referred to herein as "components"). Buyer understands and agrees that Buyer remains responsible for using its independent analysis, evaluation and judgment in designing Buyer's systems and products. Sensata data sheets have been created using standard laboratory conditions and engineering practices. Sensata has not conducted any testing other than that specifically described in the published documentation for a particular data sheet. Sensata may make corrections, enhancements, improvements and other changes to its data sheets or components without notice.

Buyers are authorized to use Sensata data sheets with the Sensata component(s) identified in each particular data sheet. HOWEVER, NO OTHER LICENSE, EXPRESS OR IMPLIED, BY ESTOPPEL OR OTHERWISE TO ANY OTHER SENSATA INTELLECTUAL PROPERTY RIGHT, AND NO LICENSE TO ANY THIRD PARTY TECHNOLOGY OR INTELLECTUAL PROPERTY RIGHT, IS GRANTED HEREIN. SENSATA DATA SHEETS ARE PROVIDED "AS IS". SENSATA MAKES NO WARRANTIES OR REPRESENTATIONS WITH REGARD TO THE DATA SHEETS OR USE OF THE DATA SHEETS, EXPRESS, IMPLIED OR STATUTORY, INCLUDING ACCURACY OR COMPLETENESS. SENSATA DISCLAIMS ANY WARRANTY OF TITLE AND ANY IMPLIED WARRANTIES OF MERCHANTABILITY, FITNESS FOR A PARTICULAR PURPOSE, QUIET ENJOYMENT, QUIET POSSESSION, AND NON-INFRINGEMENT OF ANY THIRD PARTY INTELLECTUAL PROPERTY RIGHTS WITH REGARD TO SENSATA DATA SHEETS OR USE THEREOF.

All products are sold subject to Sensata's terms and conditions of sale supplied at [www.sensata.com](http://www.sensata.com) SENSATA ASSUMES NO LIABILITY FOR APPLICATIONS ASSISTANCE OR THE DESIGN OF BUYERS' PRODUCTS. BUYER ACKNOWLEDGES AND AGREES THAT IT IS SOLELY RESPONSIBLE FOR COMPLIANCE WITH ALL LEGAL, REGULATORY AND SAFETY-RELATED REQUIREMENTS CONCERNING ITS PRODUCTS, AND ANY USE OF SENSATA COMPONENTS IN ITS APPLICATIONS, NOTWITHSTANDING ANY APPLICATIONS-RELATED INFORMATION OR SUPPORT THAT MAY BE PROVIDED BY SENSATA.

Mailing Address: Sensata Technologies, Inc., 529 Pleasant Street, Attleboro, MA 02703, USA.

## CONTACT US

### Americas

+1 (800) 350 2727  
[sensors@sensata.com](mailto:sensors@sensata.com)

### Europe, Middle East & Africa

+33 (3) 88 20 8080  
[position-info.eu@sensata.com](mailto:position-info.eu@sensata.com)

### Asia Pacific

[sales.isasia@list.sensata.com](mailto:sales.isasia@list.sensata.com)  
 China +86 (21) 2306 1500  
 Japan +81 (45) 277 7117  
 Korea +82 (31) 601 2004  
 India +91 (80) 67920890  
 Rest of Asia +886 (2) 27602006 ext 2808