

4

3

2

1

ZONE	REV.	REVISION DESCRIPTION	ECN NO.	DATE

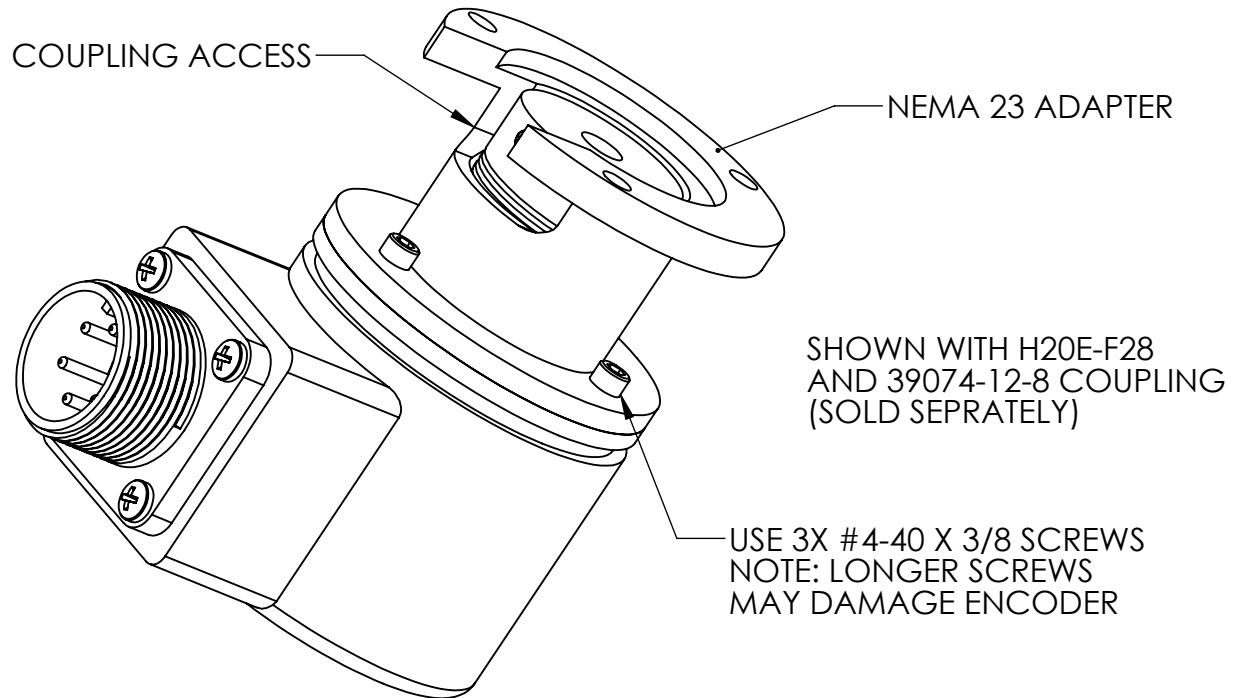
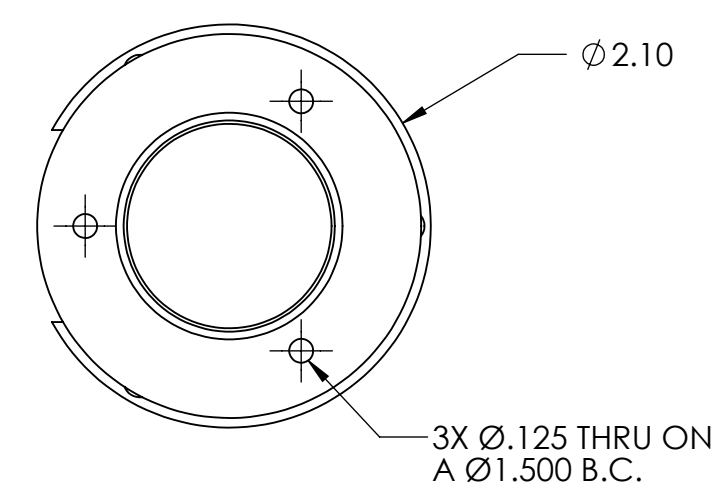
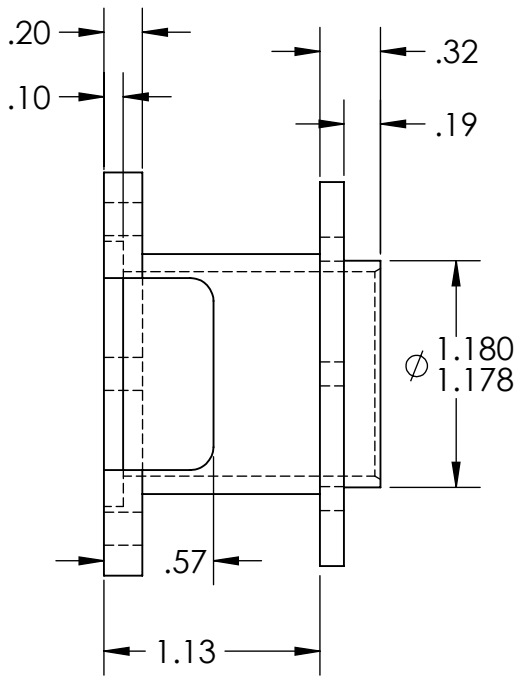
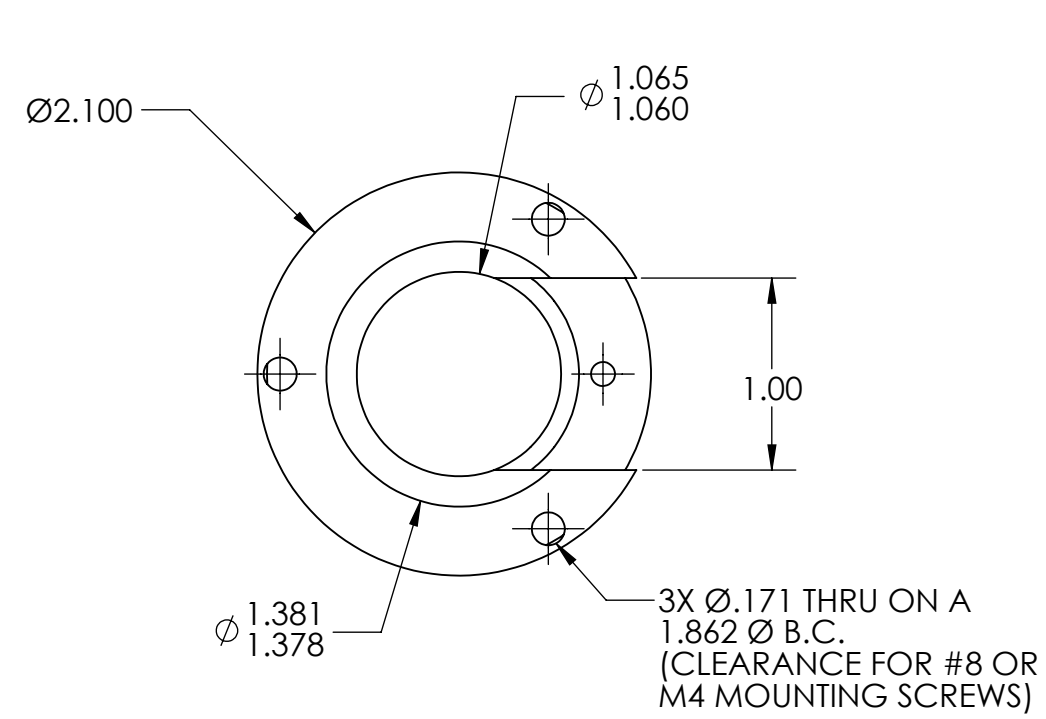

P/N 38229-001 - NEMA 23 MOTOR ADAPTER
(ENCODER AND COUPLING SOLD SEPARATELY)

UNCONTROLLED COPY		 BEI SENSORS 1461 LAWRENCE DRIVE THOUSAND OAKS, CA 93120	
FIRST ISSUE DATE: 04/18/198	SENSATA TECHNOLOGIES PROPRIETARY AND CONFIDENTIAL. NEITHER THIS PRINT NOR THE INFORMATION CONTAINED HEREON IS TO BE USED AGAINST THE INTERESTS OF SENSATA TECHNOLOGIES OR AGAINST THE INTERESTS OF ANY OF ITS AFFILIATED COMPANIES OR WHOLLY OWNED SUBSIDIARIES.	TITLE NEMA 23 MOTOR ADAPTER	
DRAWN: DRC		SIZE	DWG NO.
APPROVED: MFB		B	09907-001
DATE: 04/18/19	INTERPRET DIMENSIONING AND TOLERANCING PER ASME Y14.5-2009. UNLESS OTHERWISE SPECIFIED DIMENSIONS ARE IN INCHES [MILLIMETERS] AND ARE INTENDED AS NOMINAL SEE PRODUCT SPECIFICATIONS FOR MORE DETAILS.		REV. .
ECN:	DO NOT SCALE DRAWING	THIRD ANGLE PROJECTION	SCALE 1:1
DATE:			SOLIDWORKS
MATERIAL: ALUMINUM			SHEET 1 OF 1

4

3

2

1

DEVICE: PROJECT: