

OPTIONAL SINGLE END MOUNT KIT FOR MAXIMUM SCALE OVERALL LENGTH 610mm

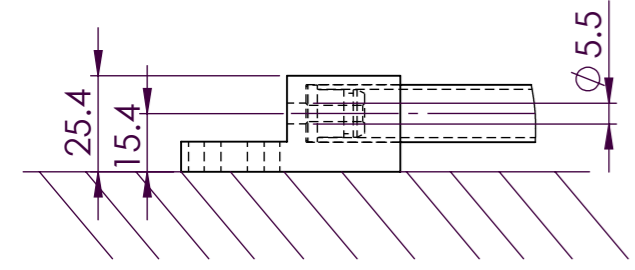

MOUNTING HOLE DETAILS
SECTION A-A
SCALE 1 : 1

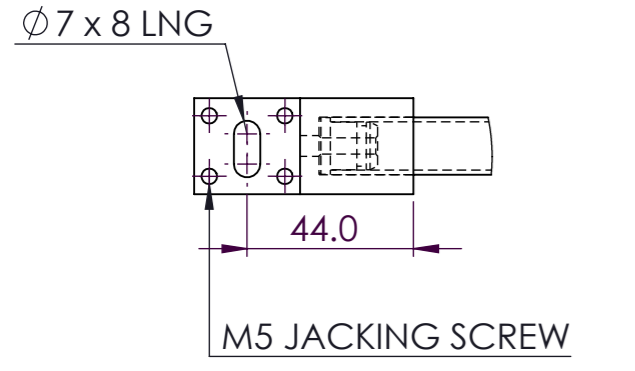
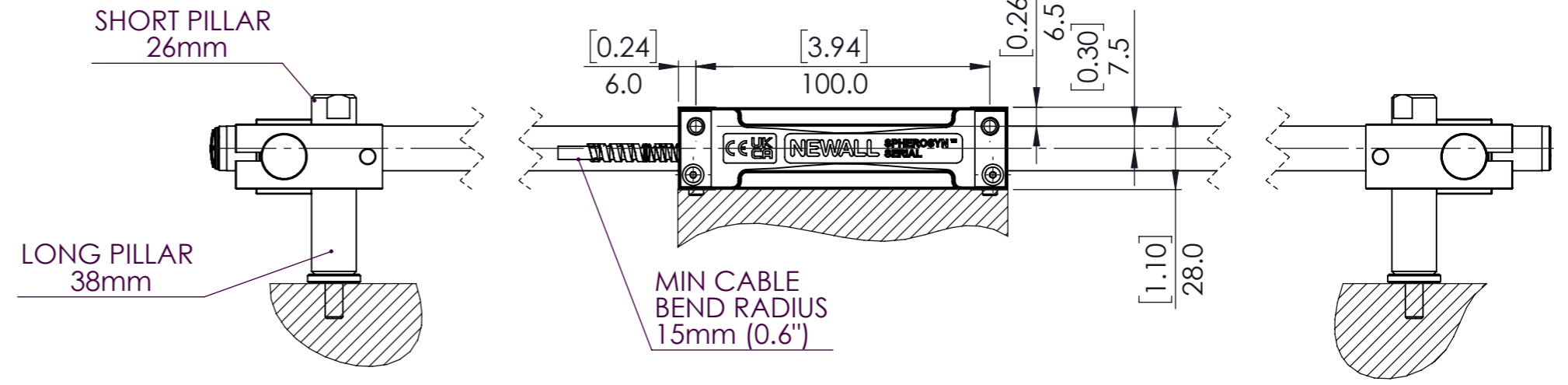
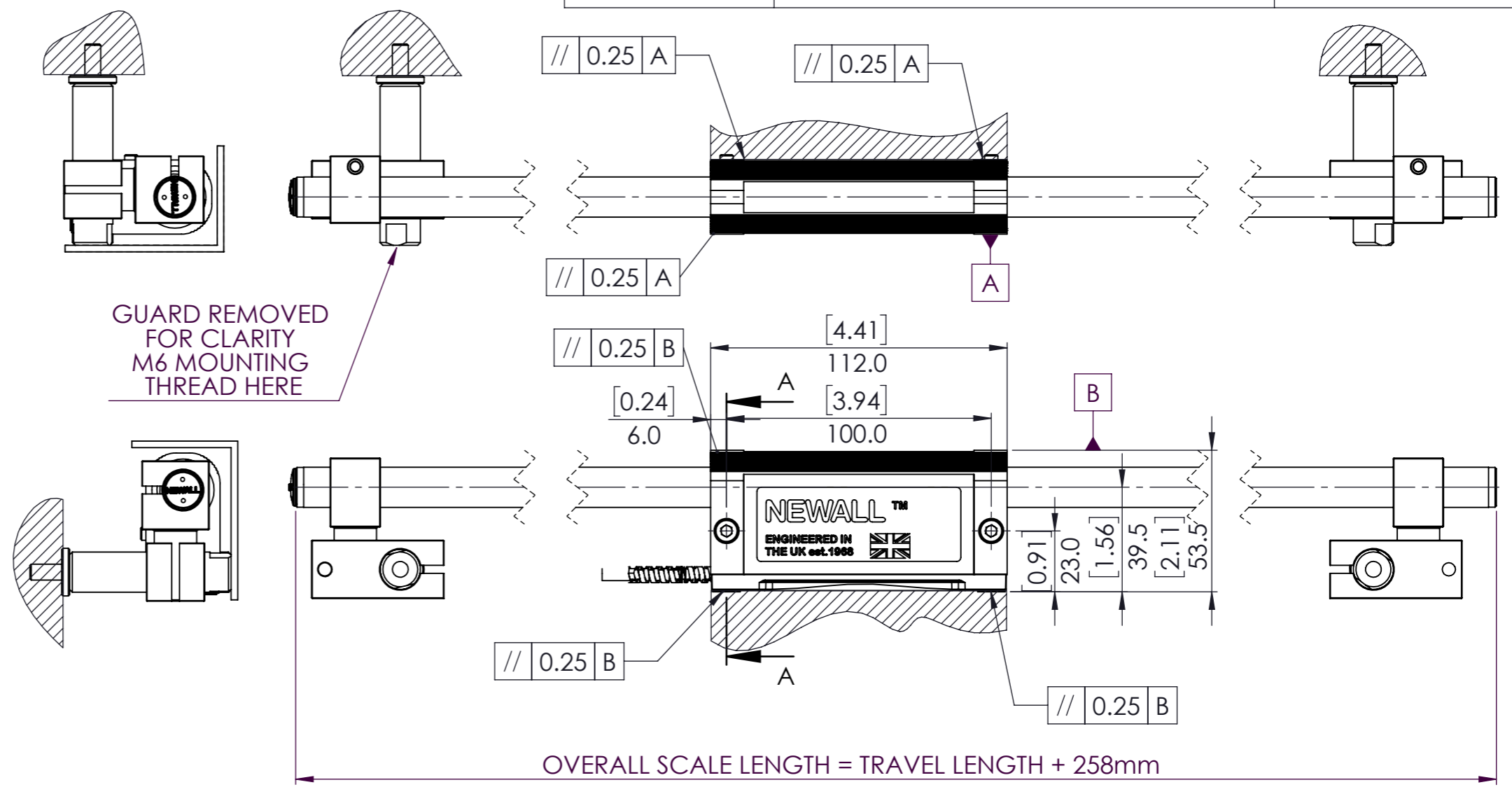
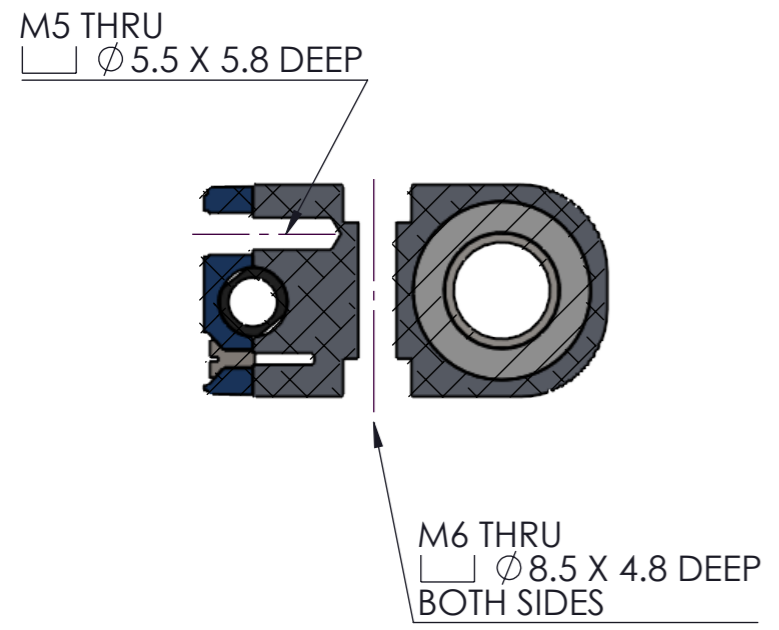

MATERIAL: N/A	NOTE: ENSURE: SHARP EDGES AND BORES ARE DEBURRED SURFACE FINISH HAS NO BLEMISHES OR SCRATCHES AND PARTS ARE CLEAN
FINISH: N/A	SCALE 1:10
WEIGHT: KG	TOLERANCES:- 0 DECIMAL PLACES ±0.5 1 DECIMAL PLACE ±0.2 2 DECIMAL PLACES ±0.1 ANGULAR ±1°

REV	DATE	ECO	ALTERATION
1	20/2	A.H	HEAVY DUTY BRACKET REMOVED

TITLE: SPHEROSYN SERIAL INSTALL DRAWING

DRAWN: C. WHITMORE 20/09/2021
CHECKED:
APPROVED:

Leicester **NEWALL** England

THIS DRAWING IS THE PROPERTY OF NEWALL MEASUREMENT SYSTEMS LIMITED. THE INFORMATION THEREON MAY NOT BE COPIED OR USED WITHOUT WRITTEN PERMISSION

SHEET 1 OF 1	DRAWING NUMBER 316-88300	REV. ISS. 1
--------------	--------------------------	-------------