

| TH11 AND TH21

SELF HOLD THERMAL CUT-OUTS

Introduction

Sensata Technologies has developed the electrical self-hold temperature cut-out in order to offer a nonself resetting device, suitable for high current applications, thus fulfilling the growing need for higher safety.

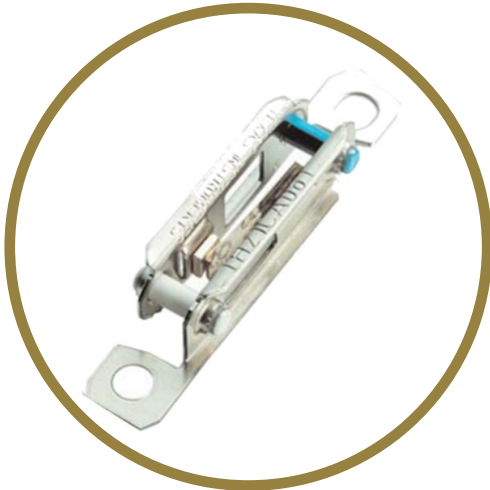

Key Benefits

- **Flexible Mounting:**
3 Terminal Configurations Available
- **Robust Design:**
The Bimetal Disc is Protected by the Metal Support
- **Full Automated Live:**
Provides Stable Setting Value
- **Low Price:**
The Particular Design Provides High Competitivity

Applications

The TH11 and TH21 are temperature resistive cut-outs for such applications as:

- Fan heaters
- Hand dryers
- Convector heaters

and various other applications which require a non-self resetting protector like transformers, cable reels etc.

Design and Operating Principles

The TH11 and TH21 consists of two nickel-plated supports, held together with ceramic pins. One support holds the high-performance Klixon® bimetal disc, which, in combination with the sophisticated contact system, guarantees the superior cycling performance. One ceramic pin has a layer of resistive material, functioning as a small heater when a voltage is supplied. A wide temperature range, standard 5K tolerance, different bimetal resistivity and various optional terminal configurations make the TH11 and TH21 suitable for a wide range of applications. Whereas the TH11 operates at 230 Vac. The TH21 is designed for 120 Vac applications. Because of their identical dimensions, the TH11 and TH21 can be easily exchanged with the auto reset thermal protector TH10.

The operating principle of the TH series is both simple and effective. A current flows through the resistive Klixon® bimetal disc. When a fault condition occurs, the increased ambient temperature causes the bimetal disc to snap open the contacts. The resistive layer spots the voltage over the open contacts and a current flows through the resistor, generating sufficient heat to keep the bimetal warm and the contacts open. When the power is switched off, the device cools down to a safe temperature and the contacts will close.

Standard Operating Temperature Range	From 60°C to 150°C - TH11 From 60°C to 130°C - TH21
Max. Ambient Temperature	200°C
Tolerance on Open Temperature	±5K > -20°C TH11 > -35°C TH21

Declarations TH11

Declarations to EN60730-2-9	
Purpose of the Control	Voltage Maintained Thermal Cut-Out
Construction	Incorporated, non-electric
Degree of Protection	IP00
Terminals for Ext. Conductors	For internal conductors only
Method of (Dis)Connection of Terminals	Riveting, soldering, spotwelding, springloaded contacting
Temperature Limits of the Switchhead	200°C
PTI of Insulation Materials	PTI 250
Method of Mounting	By various means in conjunction with (holes in) terminals, such that adequate creepage and clearance distances are maintained between live parts and accessible metal parts
Operating Time	For continuous operation
Type of Action	Type 2B
Reset Characteristic	Voltage maintained off-position thru heat from the heaterfilm on one ceramic pin. Device resets by interrupting the power supply.
Extent of Sensing Element	Whole control
Control Pollution Degree	Degree 2

Curves

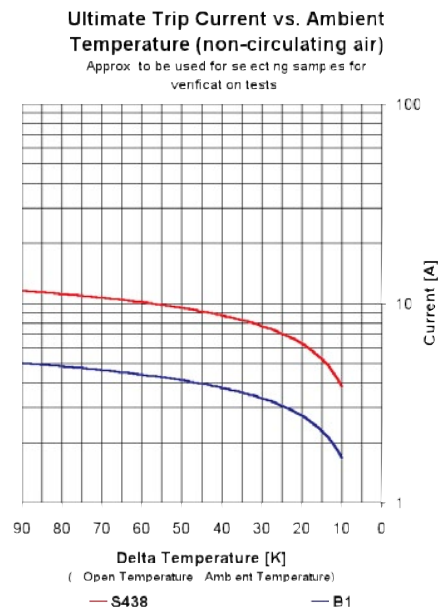



DIMENSION AND TYPES

Dimensions in mm

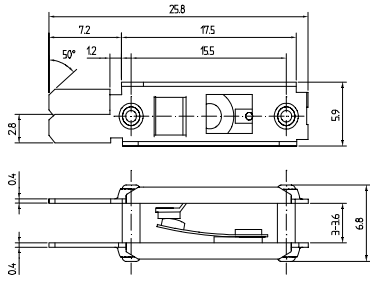

Type A

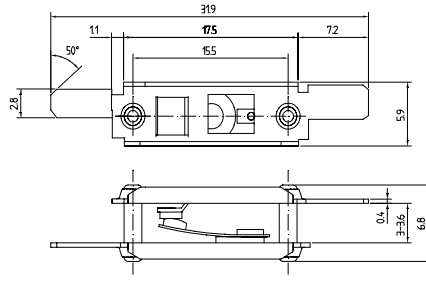

Type B

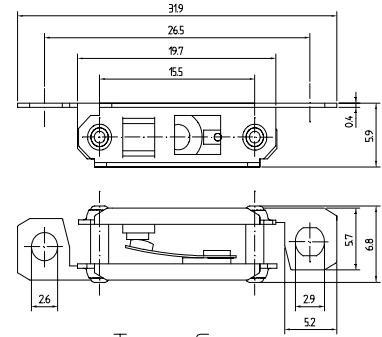

Type C



ORDERING OPTIONS

Example : TH11 C A 101

220V Selfhold, Terminals on Opposite End (With Holes), Steel, Standard Operating Temp 95°C, Low Resistivity Bimetal Disc (F30) 101, High Resistivity Bimetal Disc (B1) 105.

Function _____ **TH11** **X** **Y** **Z**

11	220V Selfhold
21	110V Selfhold

Terminal Configuration _____

Code	Max. Ambient Temperature
A	Terminals on Same End
B	Terminals on Opposite End
C	Terminals on Opposite End (with holes)

Disc and Contact Support Material _____

Code	Material
A	Steel

Standard Opening Temperature _____

Operating Temp.	Low Resistivity Bimetal Disc. (S438)	High Resistivity Bimetal Disc. (B1)
60°C	031	035
65°C	041	045
70°C	051	055
75°C	061	065
80°C	071	075
85°C	081	085
90°C	091	095
95°C	101	105
100°C	111	115
105°C	121	125
110°C	131	135
115°C	141	145
120°C	151	155
125°C	161	165
130°C	171	175
135°C	181	
140°C	191	
145°C	201	
150°C	211	



AGENCY APPROVALS & CERTIFICATES



Agency	DEKRA
File Number	2014531.14
Rating	16(2)A 250 Vac @ 1.000 cycles,
Standard	EN60730-2-9, EN60730-1



Agency	UL
File Number	E54813

Sensata Technologies, Inc. ("Sensata") data sheets are solely intended to assist designers ("Buyers") who are developing systems that incorporate Sensata products (also referred to herein as "components"). Buyer understands and agrees that Buyer remains responsible for using its independent analysis, evaluation and judgment in designing Buyer's systems and products. Sensata data sheets have been created using standard laboratory conditions and engineering practices. Sensata has not conducted any testing other than that specifically described in the published documentation for a particular data sheet. Sensata may make corrections, enhancements, improvements and other changes to its data sheets or components without notice.

Buyers are authorized to use Sensata data sheets with the Sensata component(s) identified in each particular data sheet. HOWEVER, NO OTHER LICENSE, EXPRESS OR IMPLIED, BY ESTOPPEL OR OTHERWISE TO ANY OTHER SENSATA INTELLECTUAL PROPERTY RIGHT, AND NO LICENSE TO ANY THIRD PARTY TECHNOLOGY OR INTELLECTUAL PROPERTY RIGHT, IS GRANTED HEREIN. SENSATA DATA SHEETS ARE PROVIDED "AS IS". SENSATA MAKES NO WARRANTIES OR REPRESENTATIONS WITH REGARD TO THE DATA SHEETS OR USE OF THE DATA SHEETS, EXPRESS, IMPLIED OR STATUTORY, INCLUDING ACCURACY OR COMPLETENESS. SENSATA DISCLAIMS ANY WARRANTY OF TITLE AND ANY IMPLIED WARRANTIES OF MERCHANTABILITY, FITNESS FOR A PARTICULAR PURPOSE, QUIET ENJOYMENT, QUIET POSSESSION, AND NON-INFRINGEMENT OF ANY THIRD PARTY INTELLECTUAL PROPERTY RIGHTS WITH REGARD TO SENSATA DATA SHEETS OR USE THEREOF.

All products are sold subject to Sensata's terms and conditions of sale supplied at www.sensata.com SENSATA ASSUMES NO LIABILITY FOR APPLICATIONS ASSISTANCE OR THE DESIGN OF BUYERS' PRODUCTS. BUYER ACKNOWLEDGES AND AGREES THAT IT IS SOLELY RESPONSIBLE FOR COMPLIANCE WITH ALL LEGAL, REGULATORY AND SAFETY-RELATED REQUIREMENTS CONCERNING ITS PRODUCTS, AND ANY USE OF SENSATA COMPONENTS IN ITS APPLICATIONS, NOTWITHSTANDING ANY APPLICATIONS-RELATED INFORMATION OR SUPPORT THAT MAY BE PROVIDED BY SENSATA.

Mailing Address: Sensata Technologies, Inc., 529 Pleasant Street, Attleboro, MA 02703, USA.

CONTACT US

Americas

+1 (508) 236-2551
electrical-protection-sales@sensata.com

Europe, Middle East & Africa

+31 (74) 357 8156
nfo-sse@list.sensata.com

Asia Pacific

EP_Asia_Public@list.sensata.com
 China +86 (21) 2306 1651
 Japan +81 (45) 277 7104
 Korea +82 (53) 644 9685
 India +91 (40) 4033 9611
 Rest of Asia +65 (6478) 6860