

4

3

2

1

D

D

C

C

B

B

A

A

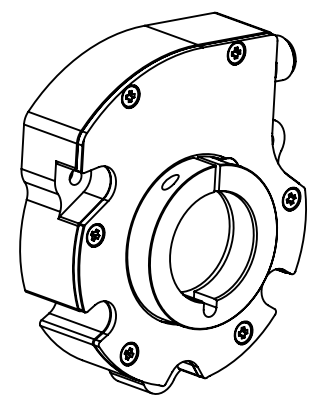
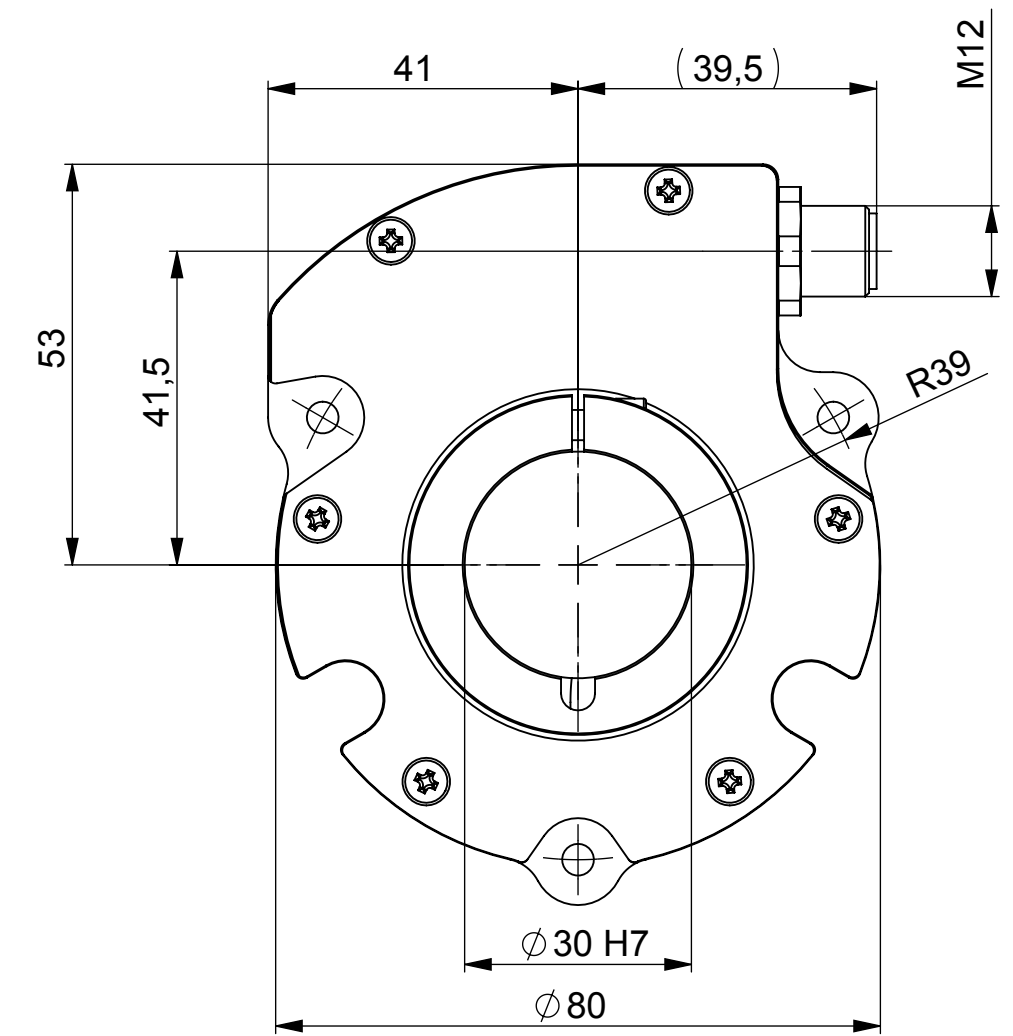
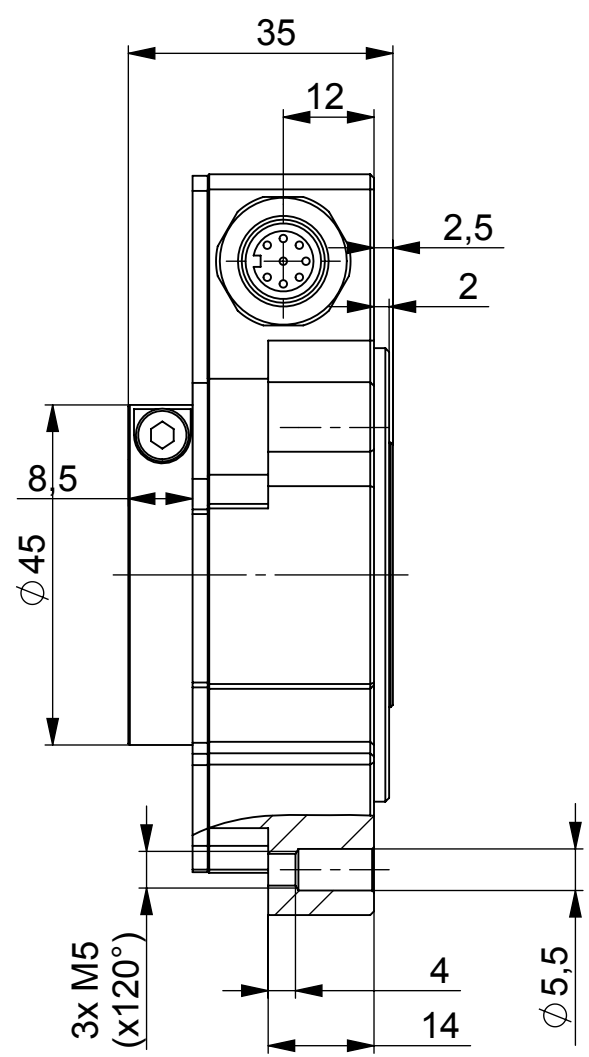
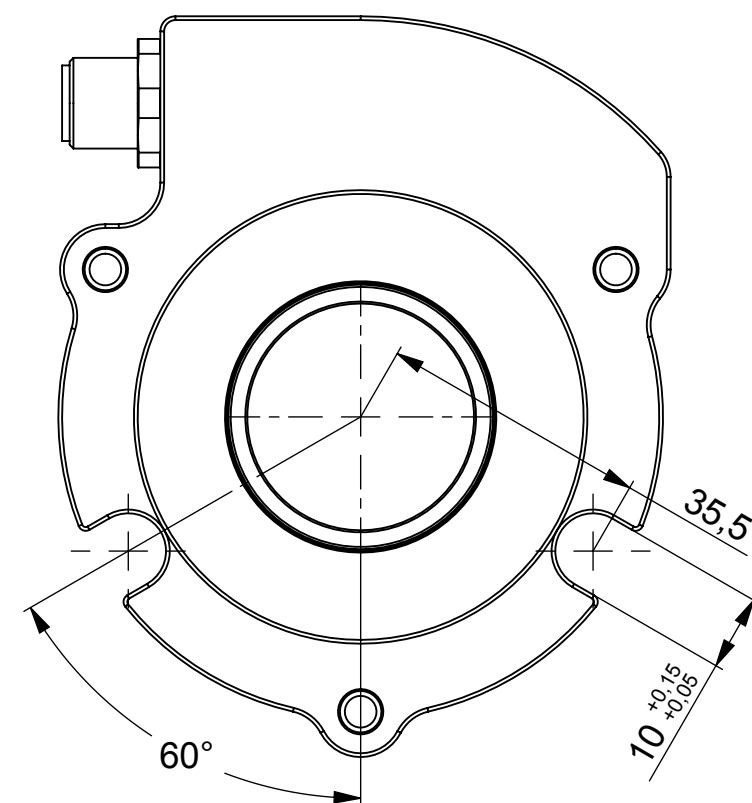

UNCONTROLLED COPY			
FIRST ISSUE DATE : 13/06/2018	SENSATA TECHNOLOGIES PROPRIETARY AND CONFIDENTIAL. NEITHER THIS PRINT NOR THE INFORMATION CONTAINED HEREON IS TO BE USED AGAINST THE INTERESTS OF SENSATA TECHNOLOGIES OR AGAINST THE INTERESTS OF ANY OF ITS AFFILIATED COMPANIES OR WHOLLY OWNED SUBSIDIARIES.	 BEI SENSORS SAS Espace Européen de l'Entreprise 9, rue de Copenhague BP 70044 - F 67013 STRASBOURG Cedex Tel : +33 (0)3 88 20 81 40	
DRAWN : RHM			
APPROVED : JHH			
DATE : 13/06/2018			
ECN :	UNLESS OTHERWISE SPECIFIED DIMENSIONS ARE IN MILLIMETERS (INCHES) AND ARE INTENDED AS NOMINAL. SEE PRODUCT SPECIFICATION FOR MORE DETAILS.	TITLE	
DATE :		HHU930//GMR	
Housing material : Aluminum	DO NOT SCALE DRAWING	EUROPEAN SYSTEM	REV. A
Flange material : Aluminum			
Shaft material : Stainless Steel			
SIZE A3		DWG NO. M042	SCALE 1/1
SCALE 1/1		SOLIDWORKS	SHEET 1 OF 1

4

3

2

1

DEVICE:

PROJECT: